

15" LCD TV
Service Manual
Model No. 15MF050V/17

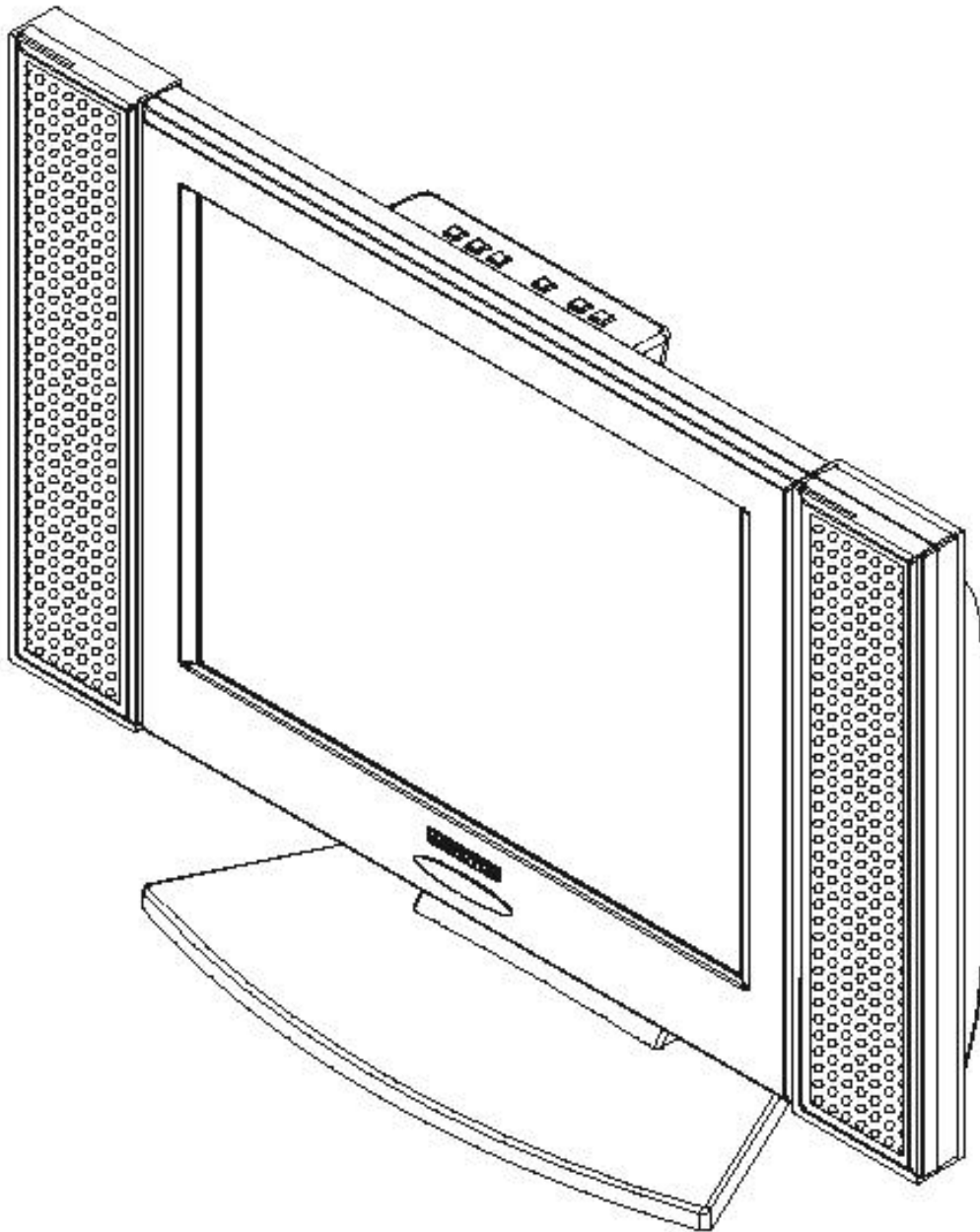

Index

| | |
|---|-----------|
| Index ----- | 1 |
| Specifications ----- | 2 |
| 1. Overview: ----- | 3 |
| 2. Hardware System ----- | 5 |
| 3 I/O interface ----- | 7 |
| 4. Appearance and Carton ----- | 9 |
| 5. Reliability test ----- | 11 |
| 15" TFT-LCD EXPLODE DRAWING ----- | 12 |
| STANDARD OPERATION PROCEDURE ----- | 13 |
| FAULT FINDING TREE ----- | 19 |
| Power supply repair flowchart ----- | 20 |
| OSD display repair flowchart ----- | 21 |
| PC mode repair flowchart ----- | 22 |
| TV mode repair flowchart ----- | 23 |
| AV, SV & YcbCr mode repair flowchart ----- | 24 |
| Audio repair flowchart ----- | 25 |
| S.K.D. ----- | 26 |
| Refrencces - AU IIS - 15 (P-grade) ----- | 28 |
| Refrencces - AUO M150XN07 ----- | 34 |

Specifications

Model No: Aplus LT1520



1. Overview:

1.1 Introduction

Aplus LM/LT series products are cutting-edge LCD TVs. Basing on advanced image processing technology and highly integrated circuit design, LM/LT series bring digital multimedia entertainment from theater to your home. This document is the detail spec of these optimized LCD TVs. We will define each sub-system except panel spec & inspection in detail. Panel spec & inspection standards aren't included in main content of this document, see attached files.

1.2 Key Features

- Wide viewing angel: Horizontal 120°~160° /Vertical 105°~150° (CR>=5, depends on acquired panel)
- High brightness (250 ~ 500 cd/m², depends on acquired panel)
- High contrast ratio (200:1 ~ 500:1, depends on acquired panel)
- Fast response time 16~25 ms (depends on acquired panel)
- XGA (1024x768 pixels) resolution
- Auto-tune image optimization for VGA
- Progressive scan(480P)
- Automatic VGA display mode detection & switching control
- 2D De-interlace function
- Bundled 2W(max) x 2 stereo speaker
- Wall-mountable design.
- Easy access top keypad controls (Menu, Volume up/down, CH up/down, Power)
- Built-in audio amplifier (3W×2)
- See References : “AU IIS-15 (P grade)” for detail.
- See References : “AU M150XN07” for detail.

1.3 System Diagram

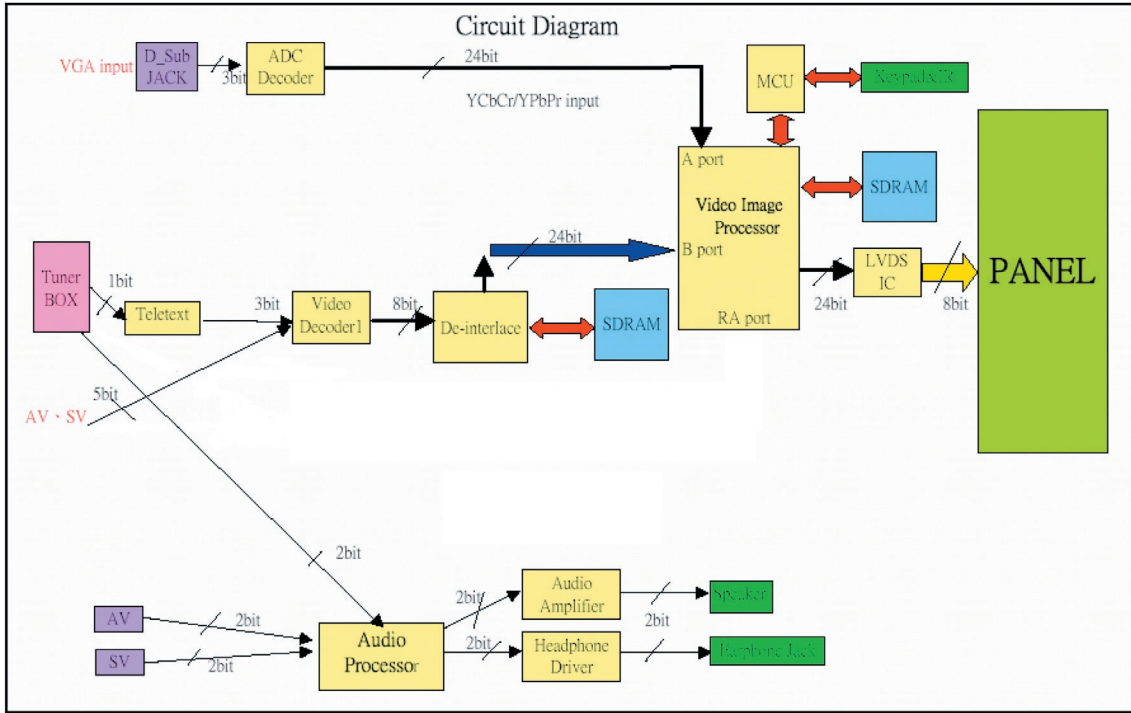

2. Hardware System

Panel

2.1 Overview

- Model: Model: AUO M150XN07
- LCD Monitor: 15" TFT-LCD Color Display (AUO)
- Screen Ratio: 4:3
- Resolution: 1024 x 768
- Display Color: 16.7 million true color display
- Brightness: 250 cd/m²
- Contrast Ratio: 400:1
- Viewing Angle (CR >= 5): Horizontal: 150°; Vertical: 145°
- Surface Treatment: Anti-glare, hard coating (3H)
- TTL 2 port interface
- Lamp life: 30,000 hour (Typ.)
- Inverter: 12V DC +/- 12%.

2.2 General spec brief

| NO | Item | Unit | Specification |
|----|---------------------------------------|----------------------|---|
| 1 | Screen diagonal | [mm] | 381(15") |
| 2 | Outline dimension | [mm] | 326.5x253.5x12.0 typ. |
| 3 | Display area | [mm] | 304.128(H)x228.096(V) |
| 4 | Resolution | | 1024(R,G,B x3)x768 |
| 5 | Pixel pitch | [mm] | 0.297x0.297 |
| 6 | Pixel Arrangement | | R.G.B. Vertical stripe |
| 7 | Display Mode | | TN mode, Normally White |
| 8 | Typical white Luminance | [cd/m ²] | 250 nit (typ.) @ 8mA |
| 9 | Brightness uniformity | | 80% typ. |
| 10 | Luminance uniformity | | 1.7 max. |
| 11 | Crosstalk(at 60Hz) | | 1.2% max. |
| 12 | Contrast Ratio | | 400:1 typ. |
| 13 | Support Colors | | 262,144 colors(6-bit for R,G,B) |
| 14 | Chromaticity(CIE1931) | White-x | 0.313 |
| | | White-y | 0.329 |
| 15 | Color Gamut | | 60% typ. of NTSC coverage |
| 16 | Viewing angle | | 60(left), 60(right), 40(up), 60(down) CR=10 |
| 17 | Response Time | [msec] | 16ms typ. (Tr+Tf) |
| 18 | Normal Input Voltage VDD | [Volt] | +3.3V |
| 19 | Power Consumption(VDD line+CCFL line) | [Watt] | 15 typ. @8mA (All Black Pattern) |
| 20 | Electrical Interface | | LVDS(1 ch) |
| 21 | Frame rate | [Hz] | 60Hz typ. 75Hz max. |
| 22 | Weight | [Grams] | 1100 typ. |
| 23 | Mounting method | | Side mounting |
| 24 | Surface Treatment | | Anti-glare, Hard Coating(3H) |
| 25 | Temperature Range | Operating | [°C] 0 to +50 |
| | | Storage (Shipping) | [°C] -20 to +60 |

2.3 Optical spec brief

| Item | Unit | Conditions | Min. | Typ. | Max. |
|-------------------------------------|----------------------|------------------------------|-------|-------|-------|
| Viewing Angle CR: Contrast Ratio | [degree] | Horizontal (Right) | 50 | 60 | |
| | | CR=10 (Left) | 50 | 60 | |
| | [degree] | Horizontal (Right) | 60 | 75 | |
| | | CR= 5 (Left) | 60 | 75 | |
| | [degree] | Vertical (Upper) | 30 | 40 | |
| | | CR=10 (Lower) | 50 | 60 | |
| [degree] | Vertical (Upper) | 60 | 70 | | |
| | CR= 5 (Lower) | 65 | 70 | | |
| Contrast ratio | | Normal Direction | 300 | 400 | - |
| Response Time | [msec] | Raising Time T on (10%-90%) | - | 4 | 6 |
| | [msec] | Falling Time T off (90%-10%) | - | 12 | 17 |
| | [msec] | Raising + Falling | - | 16 | 23 |
| Color / Chromaticity | | Red x | 0.587 | 0.617 | 0.647 |
| | | Red y | 0.317 | 0.347 | 0.377 |
| | | Green x | 0.260 | 0.290 | 0.320 |
| | | Green y | 0.563 | 0.593 | .0623 |
| | | Blue x | 0.118 | 0.148 | 0.178 |
| | | Blue y | 0.070 | 0.100 | 0.130 |
| Color Coordinates (CIE) White | | White x | 0.283 | 0.313 | 0.343 |
| | | White y | 0.299 | 0.329 | 0.359 |
| Brightness Uniformity | [%] | | 75 | 80 | - |
| White Luminance at CCFL 8.0mA | [cd/m ²] | | 200 | 250 | - |
| White Luminance at CCFL 6.5mA | | | 170 | 200 | - |
| Crosstalk (in 60Hz) | [%] | | | | 1.2 |

2.4 Defect inspection standard brief

| | Inspection Item | Specification |
|----|---------------------|---|
| 1 | Line defect | Can't be seen. |
| 2 | Bright dot | ≤ 2 dots |
| 3 | Green gright dots | ≤ 2 dots |
| 4 | Dark dot | ≤ 3 dots |
| 5 | Total dots defect | ≤ 5 dots |
| 6 | Continuous defect | Two continuous bright dots(vertical, horizontal, oblique) : ≤ 1 pair |
| | | Three or more continuous bright dots (vertical, horizontal, oblique) : Not allowed |
| | | Two continuous dark dots (vertical, horizontal, oblique) : ≤ 1 pair |
| | | Three or more continuous dark dots (vertical, horizontal, oblique) : Not allowed |
| | | Distance between 2 B dots : ≥ 15 mm |
| | | Distance between 2 D dots : ≥ 15 mm |
| | | Distance between B and D dot : ≥ 10 mm |
| 7 | Display scratch | Refer to "AU IIS-15 (P grade)- 6. Appearance specifications" for detail. |
| 8 | Dust, stain, bubble | |
| 9 | Polarizer scratch | |
| 10 | Image sticking | The image-sticking phenomenon should disappear within 45mins after displaying any pattern continuously for 16hrs under 35degreeC/95%. Do not continuously turn on the same pattern exceeding 16 hours, or it will cause LCD damage. |

*PS: Please see attached files ("AU IIS-15 (P grade)", "AU M150XN07") for detail.

3 I/O interface

3.1 Overview

- RF TV Tuner input Slot x1
- Composite video + L / R (RCA) Audio input x1
- S-Video input + Shared with Composite Audio input
- 15pin D-Sub VGA + Shared with Composite Audio input
- Earphone Audio output x1

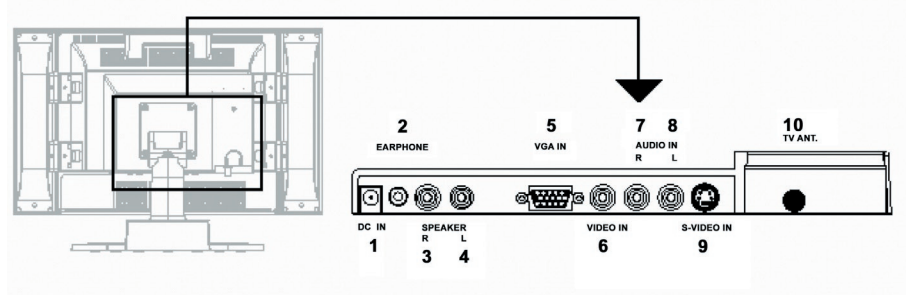

| Item | Function | Item | Function |
|------|----------------------|------|-------------------|
| 1 | DC Power Input | 6 | VIDEO Input |
| 2 | EARPHONE Output | 7 | Right AUDIO Input |
| 3 | Right SPEAKER Output | 8 | Left AUDIO Input |
| 4 | Left SPEAKER Output | 9 | S-Video Input |
| 5 | VGA Input | 10 | TV. CABLE Input |

3.2 Video Functionality

| Terminal | Type | Impedance | Audio | Connector type | Electric Characteristic |
|-------------|-----------|-----------|------------|---|---|
| RF TV Tuner | Input x 1 | 75 ohm | Stereo L/R | FPlug - NTSC | <ul style="list-style-type: none"> • AGC: 1Vpp, 18/56 ohm, -6 dB ~ +3dB. • Position: Back side |
| Composite | Input x 1 | 75 ohm | Stereo L/R | Video: RCA (Yellow) Audio: RCA (R:Red,L:White) | <ul style="list-style-type: none"> • PAL / NTSC auto detect • 1 Vp-p/ 75Ω • AGC: 1Vpp, 18/56 ohm, -6 dB ~ +3dB. • Position: Back side |
| S-Video | Input x 1 | 75 ohm | Stereo L/R | Video: Y/C Mini-Din Audio: Shared with YCbCr | <ul style="list-style-type: none"> • PAL / NTSC auto detect • Y: 1 Vp-p/75Ω, C: 0.286 Vp-p/75Ω • AGC: 1Vpp, 18/56 ohm, -6 dB ~ +3dB. • Position: Back side • Shared with Composite |
| VGA | Input x 1 | 75 ohm | Stereo L/R | VGA: 15pin D-Sub (Blue) Audio: Shared with Composite | <ul style="list-style-type: none"> • Resolution mode auto detect. • RGB 0.7 Vp-p/75Ω, H/Vsync 4.0 Vp-p/TTL Polarity, Composite sync 4.0 Vp-p/TTL Level, G sync 0.3 Vp-p/75Ω Negative Polarity • Position: Back side • Shared with Composite |

3.3 Audio Functionality

| Terminal | Type | Impedance | Audio | Connector type | Electric Characteristic |
|--------------------|------------|-----------|------------|-------------------------------|---|
| Earphone | Output x 1 | 32 ohm | Stereo L/R | Earphone 3.5fMini Jack x 1 | <ul style="list-style-type: none"> • Volume adjustable by OSD. • Position: Back side |
| Speaker | Output x 2 | 8 ohm | Stereo L/R | RCA x 2 (R:Red, L:White) | <ul style="list-style-type: none"> • Position: left & right hand side • Max output power: 2W • RMS power: 1.4W |
| Internal amplifier | Output x 1 | 4 ohm | Stereo L/R | NA | <ul style="list-style-type: none"> • Power: 3W • Frequency range: 100Hz ~ 20KHz • Position: Internal |

3.4 TOP keypad

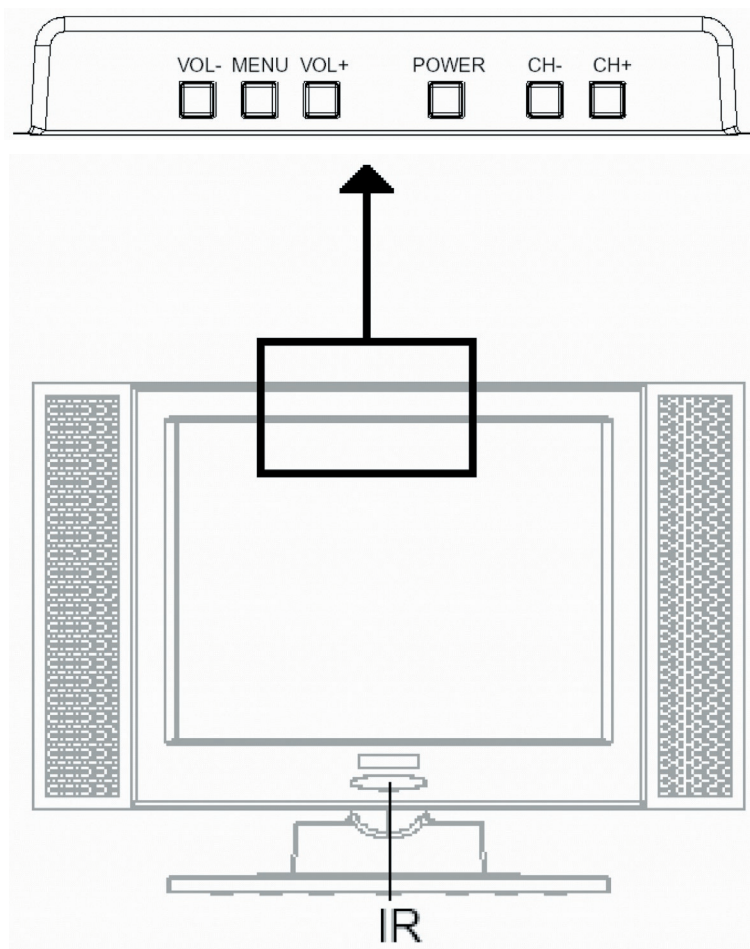

| Item | Key Name | Function |
|------|----------|---|
| 1 | VOL- | Decrease volume level button. |
| 2 | Menu | Display OSD MENU or Selects command function button. |
| 3 | VOL+ | Increase volume level button. |
| 4 | POWER | Logical power on/off LCD TV. |
| 5 | CH- | TV channel down button. |
| 6 | CH+ | TV channel up button. |
| 7 | IR | Remote IR detect windows.Receive IR signal from Remote Control. |

4. Appearance and Carton

4.1 LCD TV dimension (unit:mm)

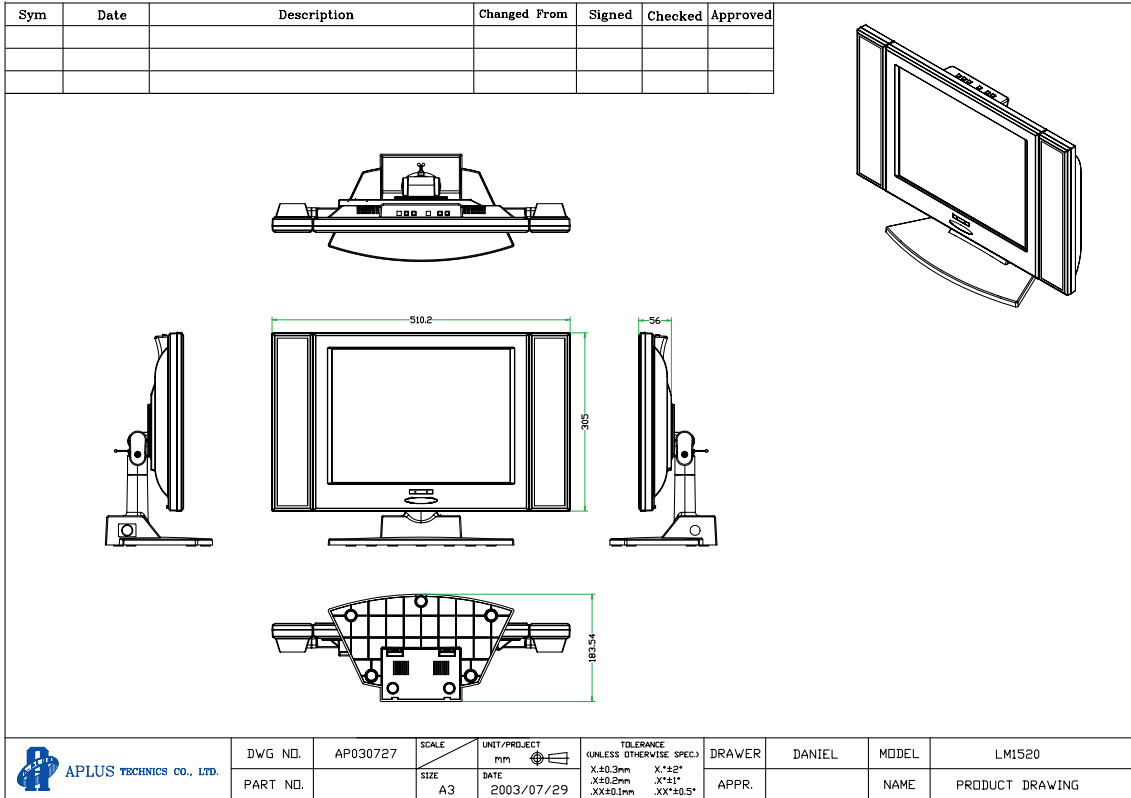

4.2 Package dimension

- 582 (W) × 446 (H) × 238 (D) mm

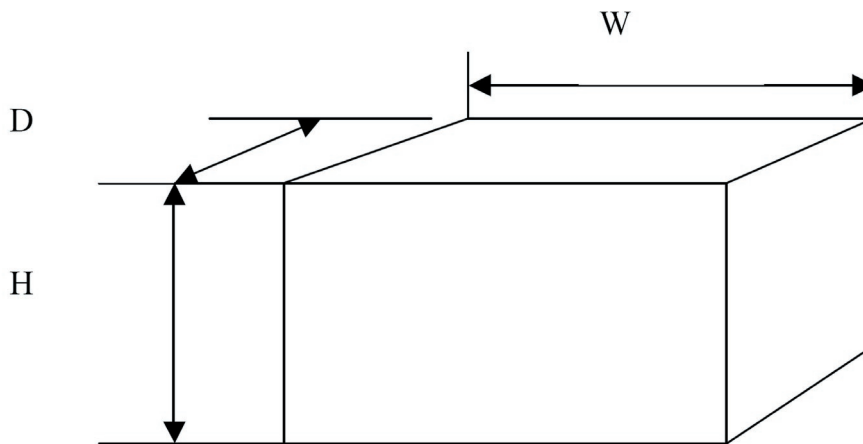

- Die Cut
- Gift box 740 (W) x 530 (H) x 235 (D) mm
 - Measurement: 3.3 CUFT, 0.094 CBM
 - Net weight: 9 Kg (LCD TV only)
 - Gross weight: 10 Kg (include LCD TV & accessories)

| Rev | Date | Description | Checked | Drawn | Checked | Approved |
|-----|------|-------------|---------|-------|---------|----------|
| | | | | | | |
| | | | | | | |

NOTES:
 1. MATERIAL : CS-3 , 5 PLYS AB-FLUTE(260A+100+100+130+250A)
 THICKNESS =7.5mm
 2. COMBINE WITH NAIL

A 2D die-cut diagram of the gift box. Dimensions are shown in red: 740 (width), 530 (height), 235 (depth), 175 (flap height), 80 (flap width), and 30 (glue flap width). The diagram shows the layout of the box panels, including the top, bottom, and side flaps.

| | | | | | | |
|-------|----------|-------|------------|---------|--------|----------|
| | DWG NO. | SCALE | SECURITY | PACKAGE | DRAWER | MODEL |
| APLUS | PART NO. | X | 2004/06/07 | ANDY | LM2010 | GIFT BOX |

4.3 Packing detail

- LCD TV Unit
- Accessories:
 - Power cord
 - Remote Controller
 - Recyclable Battery (for remote controller) AAA x 2
 - User's manual
 - Composite RCA cable (optional)
 - VGA cable (optional)
 - VGA audio input cable (optional)
 - YCbCr/YPbPr to VGA convert cable (optional)

5. Reliability test

- Outsourcing tested by "Electronics Testing Center, Taiwan".
(See: http://www.etc.org.tw/default_en.htm)

5.1 Temperature test

- Operating: 0 and 50°C for 96 hours
- Storage: -20°C and 60°C for 96 hours

5.2 Humidity test

- Operating: 40°C RH=85% for 96 hours

5.3 Thermal shock test

- Operating: 10 cycles of TA = -20°C to TB = +60°C
- Dwell time = exposure time = 30min, 10 cycles.

5.4 Non Operating Random Vibration Test (Packaged)

- Frequency: 10~200Hz
- Acceleration: 1.15gRMS
- Time: Bottom 30 minutes, Top, Left, Right, Front, Back 10 minutes.

5.5 Packing Drop Test

- Height: Corner and Edge 50cm
- Face 81.3 cm
- 1 Corners – 3 Edges – 6 Faces

15" TFT-LCD EXPLODE DRAWING

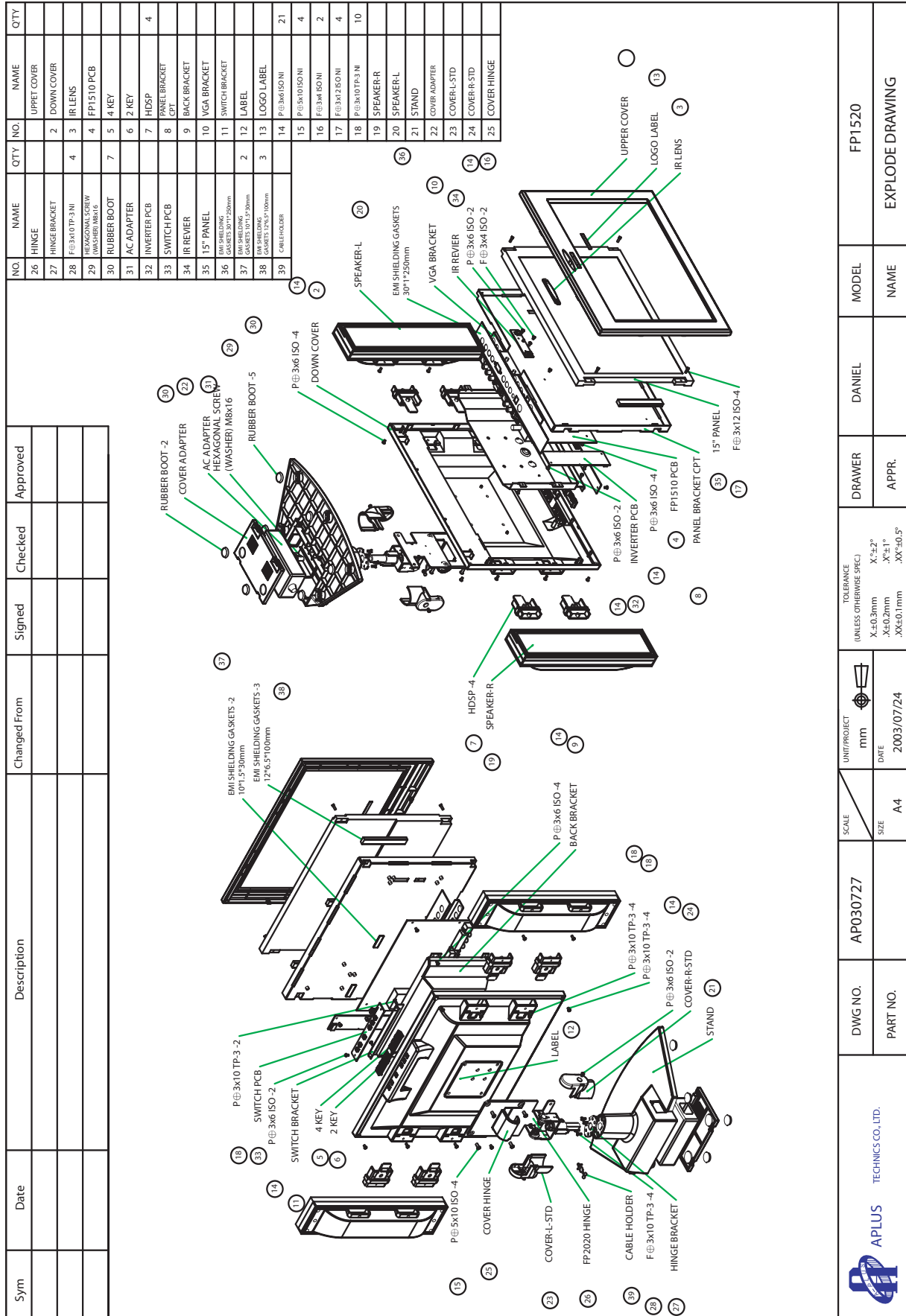

| DWG NO. | AP030727 | SCALE | A4 | UNIT/PROJECT | m/m | DATE | 2003/07/24 | TOLERANCE (UNLESS OTHERWISE SPEC) | X:±0.3mm | Y:±0.2° | Z:±1° | XX:±0.1mm | YY:±0.5° | MODEL | DANIEL | NAME | EXPLODE DRAWING |
|---------|----------|-------|----|--------------|-----|------|------------|-----------------------------------|----------|---------|-------|-----------|----------|-------|--------|------|-----------------|
| DRAWER | APPR. | | | | | | | | | | | | | MODEL | DANIEL | NAME | EXPLODE DRAWING |
| | | | | | | | | | | | | | | | | | |



STANDARD OPERATION PROCEDURE

Refer to the picture at right side.(P+5*12 ISO BK, 4 pcs)

A).Disassembly Stand(AA1301380)

Take the screw(EA0304811) off.

B.)Assembly Stand(AA1301380)

Put the screw(EA0304811) on. (Torsion :6~7KG)

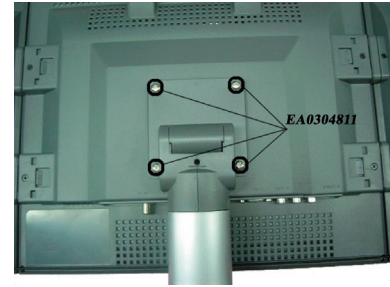

Refer to the picture at right side.(III+3*10 TP-3 BK, 4 pcs)

A).Disassembly Speaker(L:WA1000128,R:WA1000129)

1)Take the audio cable off.

2)Take the screw(EA1502011) off.

B.)Assembly Speaker(L:WA1000128,R:WA1000129)

1)Put the screw(EA1502011) on. (Torsion :4~5KG)

2)Insert the audio cable.

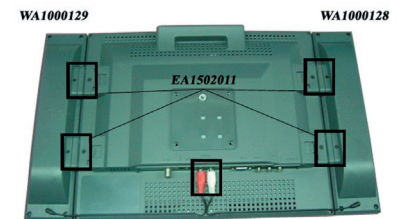

Refer to the picture at right side.(P+3*10 TP3 BK, 4pcs)

A).Disassembly

1)Take the screw(EA0305111) off.

B.)Assembly

1)Put the screw(EA0305111) on. (Torsion :4~5KG)

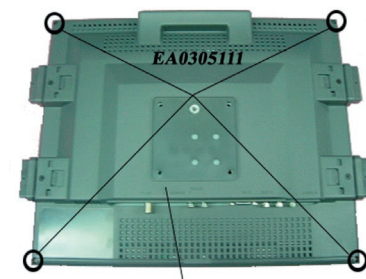

Refer to the picture at right side.

A).Disassembly LCD front cover(AA1301331)

B.)Assembly LCD front cover(AA1301331)

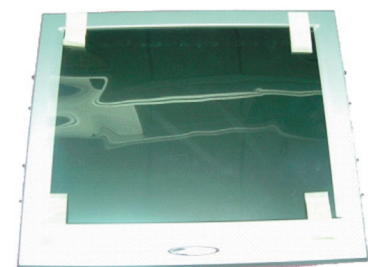

Refer to the picture at right side.(P+3*8 TP3 NI, 4pcs)

A).Disassembly

1)Take the screw(EA0301511) off.

B.)Assembly

1)Put the screw(EA0301511) on. (Torsion :4~5KG)

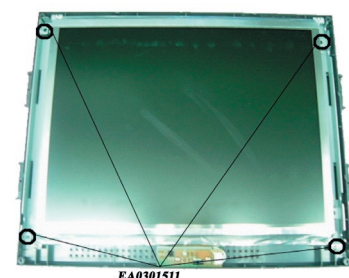

Refer to the picture at right side.

- A).Disassembly LCD back cover(**AA1302452**)
- B.)Assembly LCD back cover(**AA1302452**)



Refer to the picture at right side.

- A).Disassembly
 - 1)Take the tape off.
- B.)Assembly
 - 1)Put the tape on.

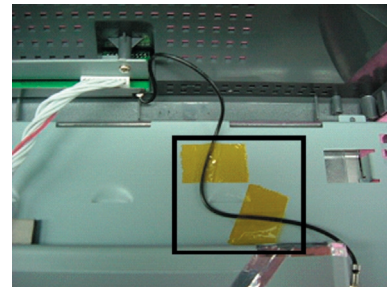

Refer to the picture at right side.(**P+3*6 ISO, 4 pcs**)

- A).Disassembly EMI metal board(**EK0605111**)
 - 1)Take the screw(**EA0301211**) off.
 - 2)Take the EMI metal board(**EK0605111**) off.
- B.)Assembly EMI metal board(**EK0605111**)
 - 1)Put the EMI metal board(**EK0605111**) on.
 - 2)Put the screw(**EA0301211**) on. (Torsion :**4~5KG**)

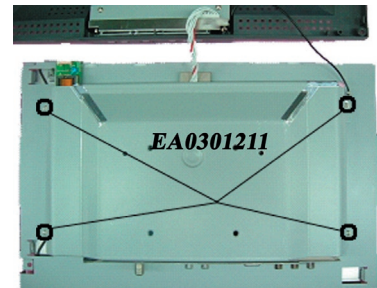

Refer to the picture at right side.

- A).Disassembly notes
 - 1)Keep the conductive shielding gasket(**MF4100031**) well.
- B.)Assembly notes
 - 1)Keep the conductive shielding gasket states (**MF4100031**) just like the picture.

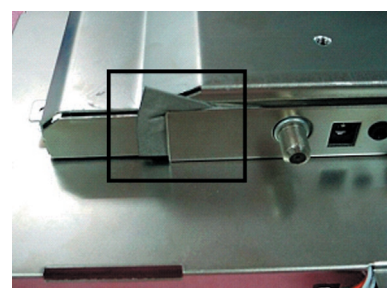

Refer to the picture at right side.(**4#40*4.8 , 2 pcs**)

- A).Disassembly VGA screw from Main board.
 - 1)Take the VGA screw(**EC0500781**) off.
- B.)Assembly VGA screw on Main board.
 - 1)Put the VGA screw(**EC0500781**) on. (Torsion :**5~6KG**)

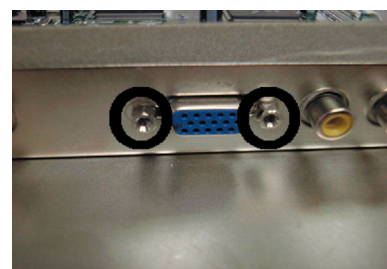

Refer to the picture at right side.(P+3*6 ISO NI, 2 pcs)

A).Disassembly INVERTER PCB(ZA2080002)

- 1)Take the cables off.
- 2)Take the screw(EA0301211) off.

B.)Assembly INVERTER PCB(ZA2080002)

- 1)Put the screw(EA0301211) on. (Torsion :4~5KG)
- 2)Insert the cables.

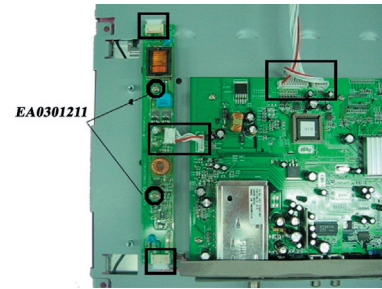

Refer to the picture at right side.(P+3*6 ISO NI, 5 pcs)

A).Disassembly Main board.(WA2109176)

- 1)Take the screw(EA0301211) off.

B.)Assembly Main board.(WA2109176)

- 1)Put the screw(EA0301211) on. (Torsion :4~5KG)

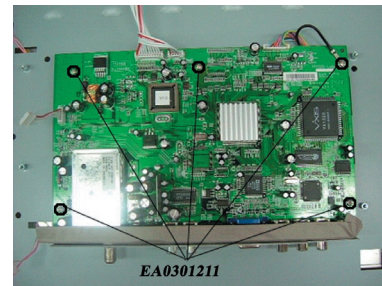

Refer to the picture at right side.

Main Board - FP1520 NTSC + V CHIP PCB.
(WA2109176)

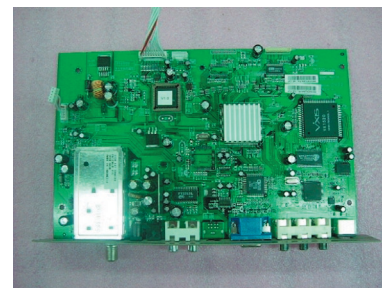

Refer to the picture at right side.

A).Disassembly

- 1)Take the Aluminum foil stickets(MG7400001~8) off.

B.)Assembly

- 1)Put the Aluminum foil stickets(MG7400001~8) on.

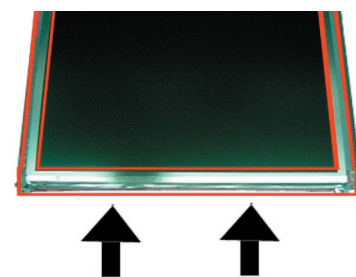

Refer to the picture at right side.(P+3*6 ISO NI, 4 pcs)

A).Disassembly LCD metal board(EK0605011)

- 1)Take the screw(EA0301211) off.

B.)Assembly LCD metal board(EK0605011)

- 1)Put the screw(EA0301211) on. (Torsion :4~5KG)

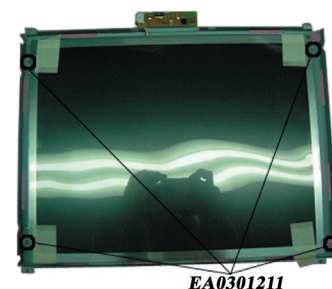

Refer to the picture at right side.

A).Disassembly

1)Take the cables off.

B.)Assembly

1)Put the cables on.

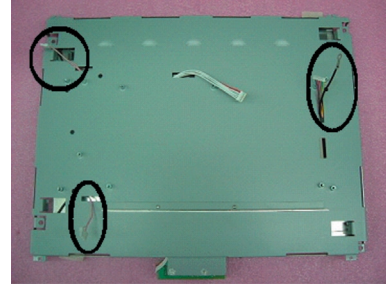

Refer to the picture at right side.

A).Disassembly Panel(**VB1503251-1**)

1)Take the **LVDS cable(BR0935006)** and screw off.

B.)Assembly Panel(**VB1503251-1**)

1)Put the **LVDS cable(BR0935006)** and screw on.

(Torsion :**4~5KG**)

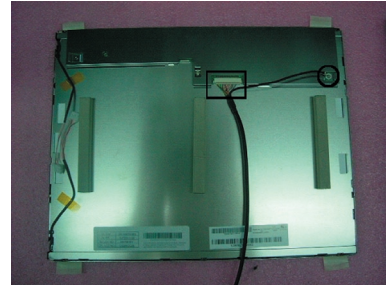

Refer to the picture at right side.(**P+3*10 TP-3 BK, 2 pcs**)

A).Disassembly KEYPAD (**WA2109051**)

1)Take the screw(**EA0305111**) off.

B.)AssemblyKEYPAD (**WA2109051**)

1)Put the screw(**EA0305111**) on. (Torsion :**4~5KG**)

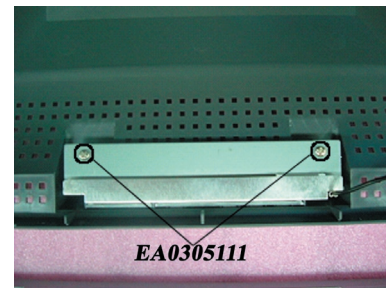

Refer to the picture at right side.(**P+3*6 ISO NI, 2 pcs**)

A).Disassembly

1)Take the screw(**EA0301211**) off.

B.)Assembly

1)Put the screw(**EA0301211**) on. (Torsion :**4~5KG**)

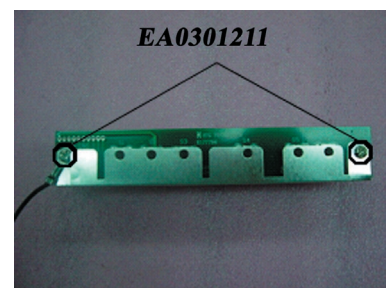

Refer to the picture at right side.

A).Disassembly

1)Take the KEYPAD(**WA2109051**) off from switch metal board(**EK1401301**).

B.)Assembly

1)Put the KEYPAD(**WA2109051**) and switch metal board(**EK1401301**) together.

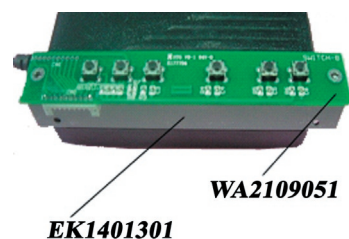

Refer to the picture at right side.(R:2 Key, L:4 Key)

A).Disassembly

1)Take the 2 Key(**AA1301360**) and 4 Key(**AA1301350**) off.

B.)Assembly

1)Put the 2 Key(**AA1301360**) and 4 Key (**AA1301350**) on.

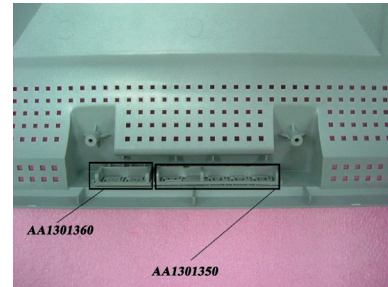

Refer to the picture at right side.

A).Disassembly

1)Take the tape off.

B.)Assembly

1)Put the tape on.

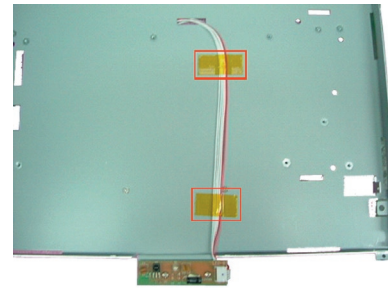

Refer to the picture at right side.(P+3*6 ISO)NI, 2 pcs)

A).Disassembly IR RECEIVER(**WA2109050**)

1)Take the cables(**JM0001211**) off.

2)Take the screw(**EA0301211**) off.

B.)Assembly IR RECEIVER(**WA2109050**)

1)Put the screw(**EA0301211**) on. (Torsion :4~5KG)

2)Insert the cables(**JM0001211**) .

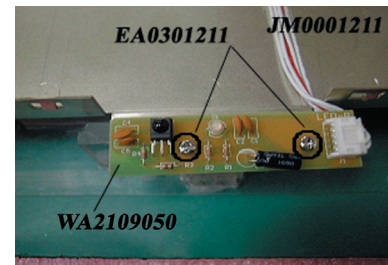

Refer to the picture at right side.(M3*4, 2 pcs)

A).Disassembly VGA metal board(**EK1401201**)

1)Take the screw(**EA1500611**) off.

B.)Assembly VGA metal board(**EK1401201**)

1)Put the screw(**EA1500611**) on. (Torsion :4~5KG)

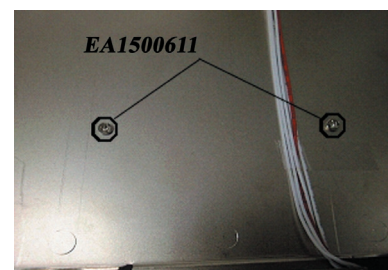

Refer to the picture at right side.(GG0000131, 5 pcs)

1)Rubber stickets 19*4 (**GG0000131**)

2)Power cover (**AA1300920**)

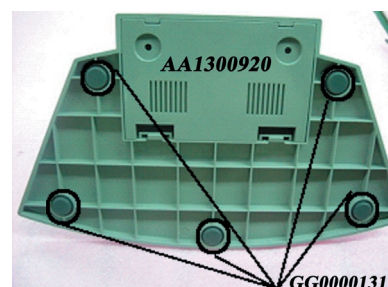

Refer to the picture at right side.(P+3*6 ISO BK, 1 pcs)

A).Disassembly

1)Take the screw(EA0304911) off.

B.)Assembly

1)Put the screw(EA0304911) on. (Torsion :4~5KG)



Refer to the picture at right side.(P+3*6 ISO BK, 1 pcs)

A).Disassembly

1)Take the screw(EA0304911) off.

B.)Assembly

1)Put the screw(EA0304911) on. (Torsion :4~5KG)

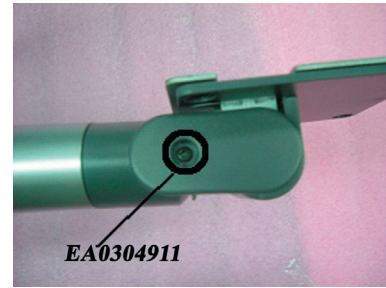

Refer to the picture at right side. (From Left to Right)

1)HINGE left cover.(AA1302490)

2)FP2010 HINGE cover.(AA1302510)

3)HINGE right cover.(AA1302500)

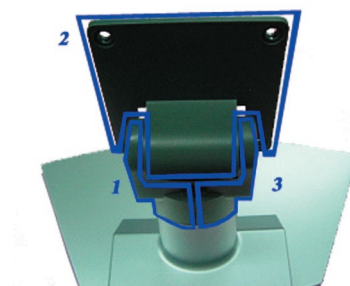

Refer to the picture at right side.(P+3*12 TP-3 NI, 4 pcs)

A).Disassembly HINGE(ER1300601)

1)Take the screw(EA0302511) off.

2)Take HINGE from Stand(AA1301380).

B.)Assembly HINGE(ER1300601)

1)Put HINGE on Stand(AA1301380)

2)Put the screw(EA0302511) on. (Torsion :5~6KG)



FAULT FINDING TREE

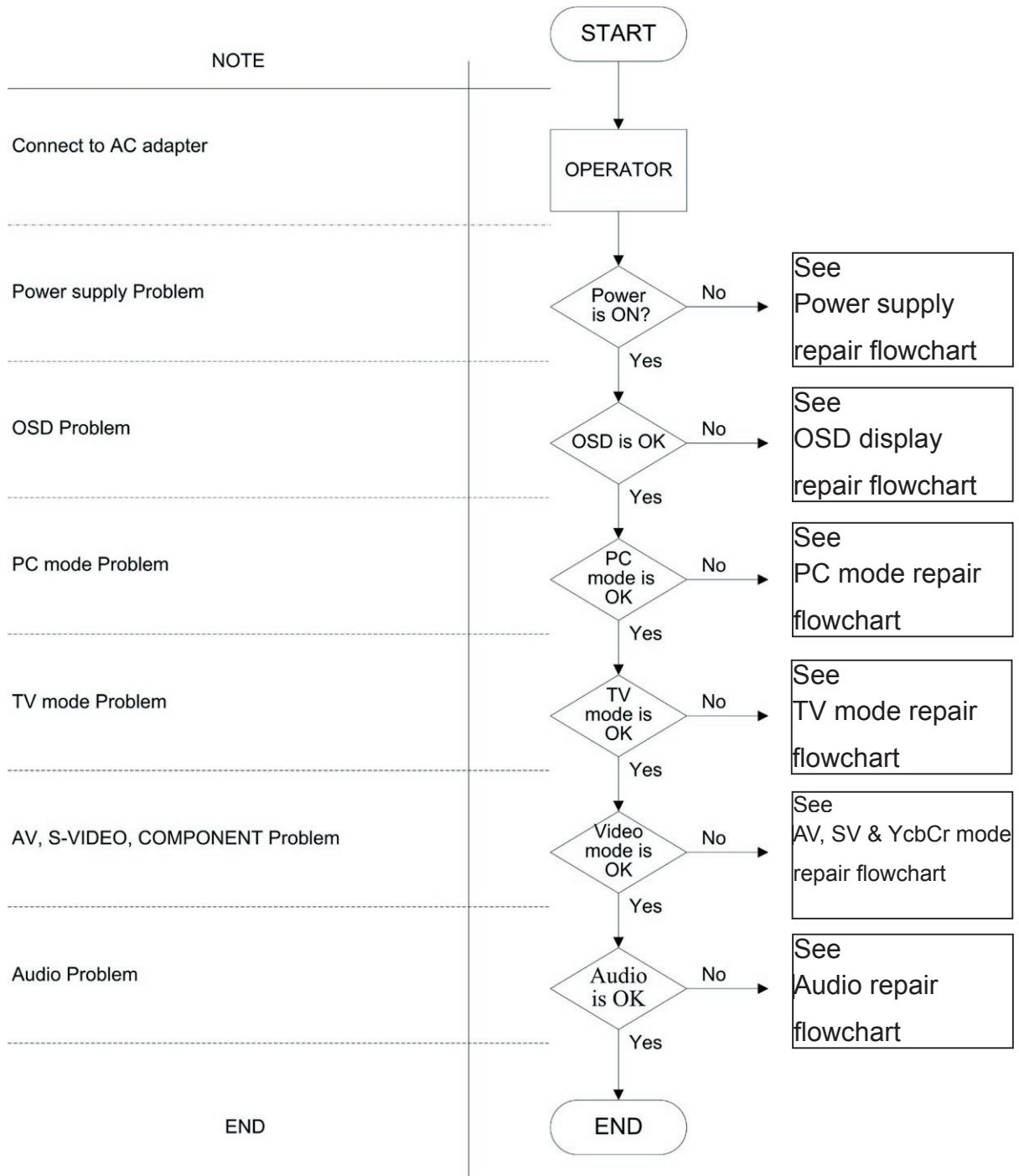

Power supply repair flowchart

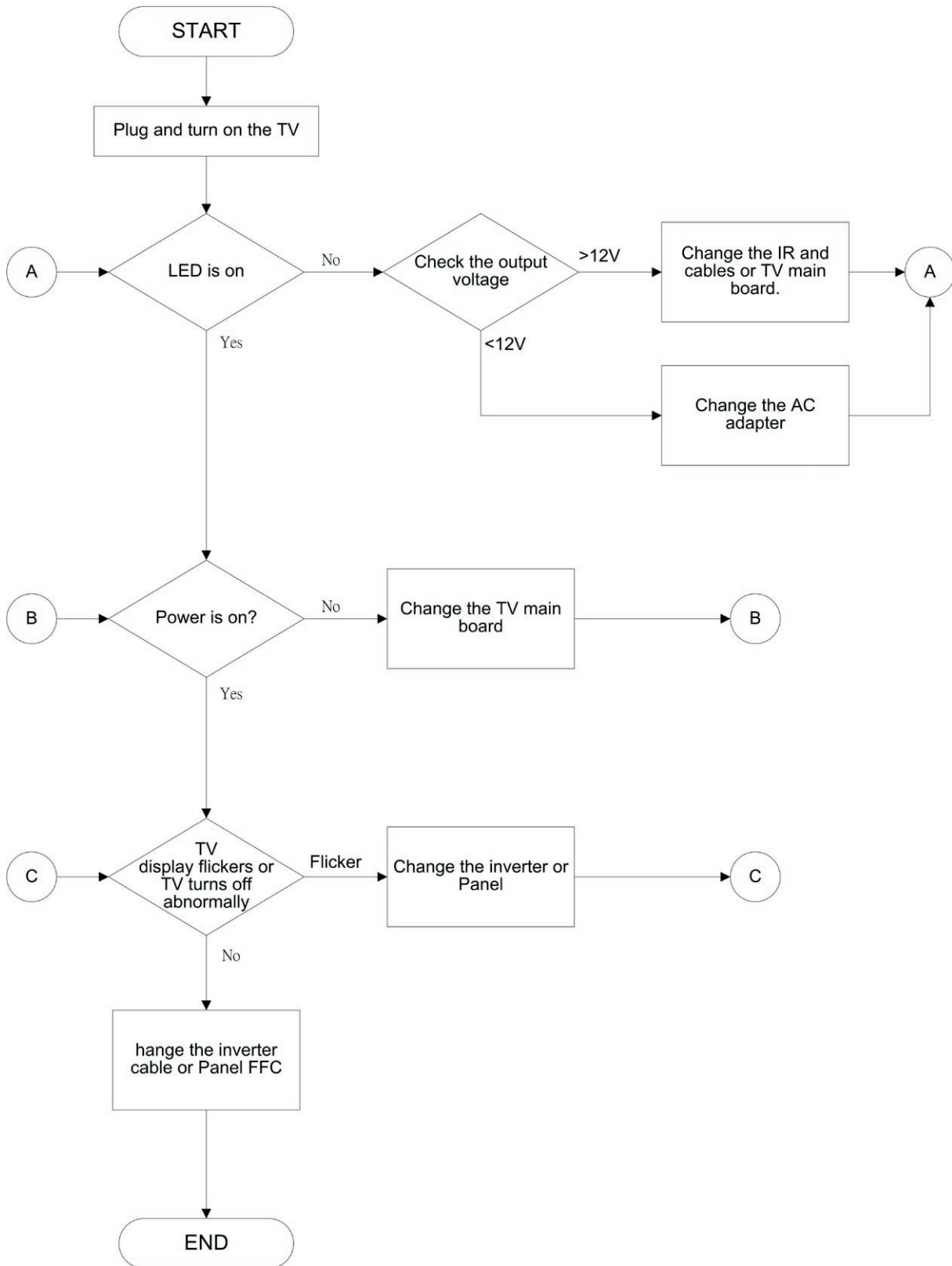

OSD display repair flowchart

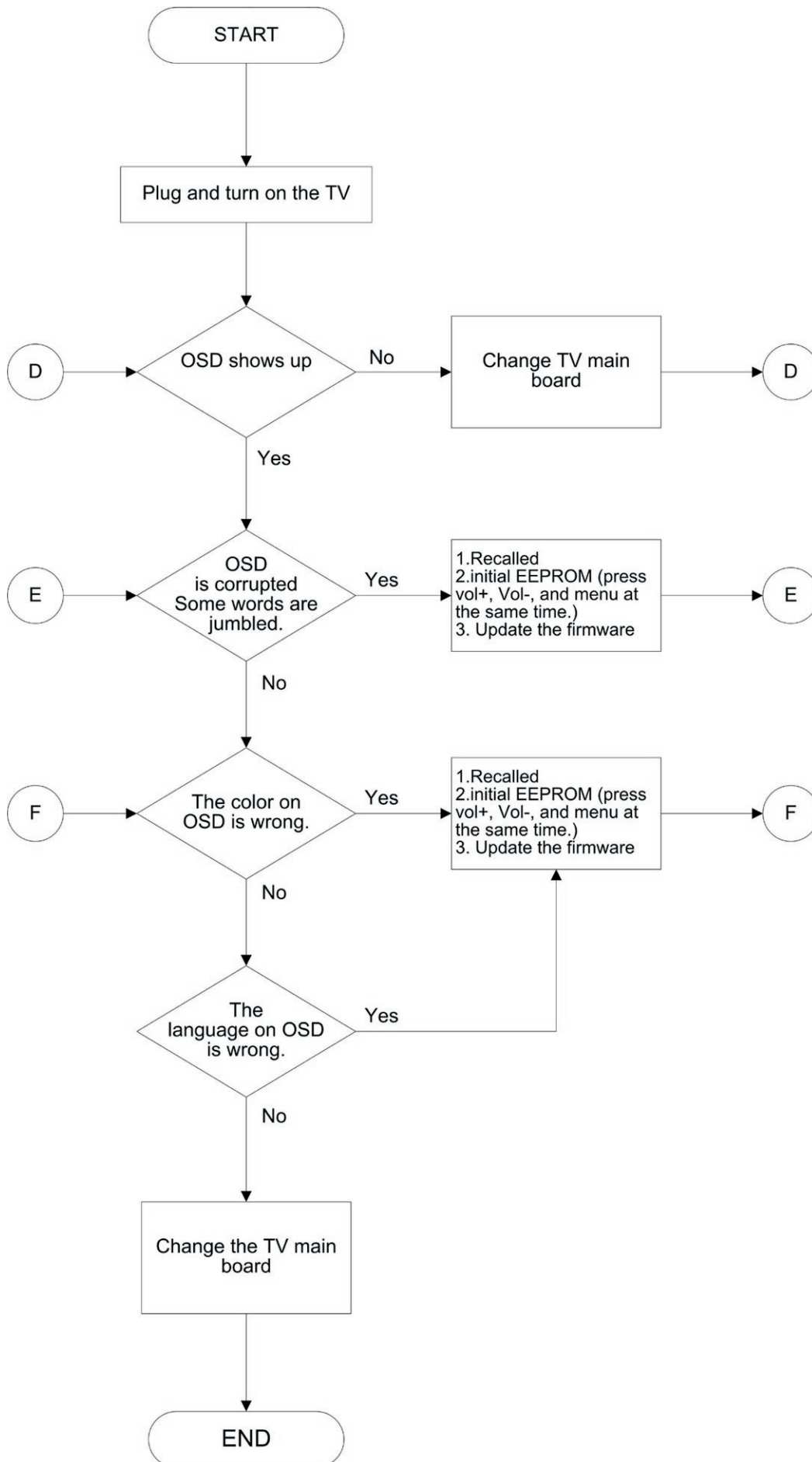

PC mode repair flowchart

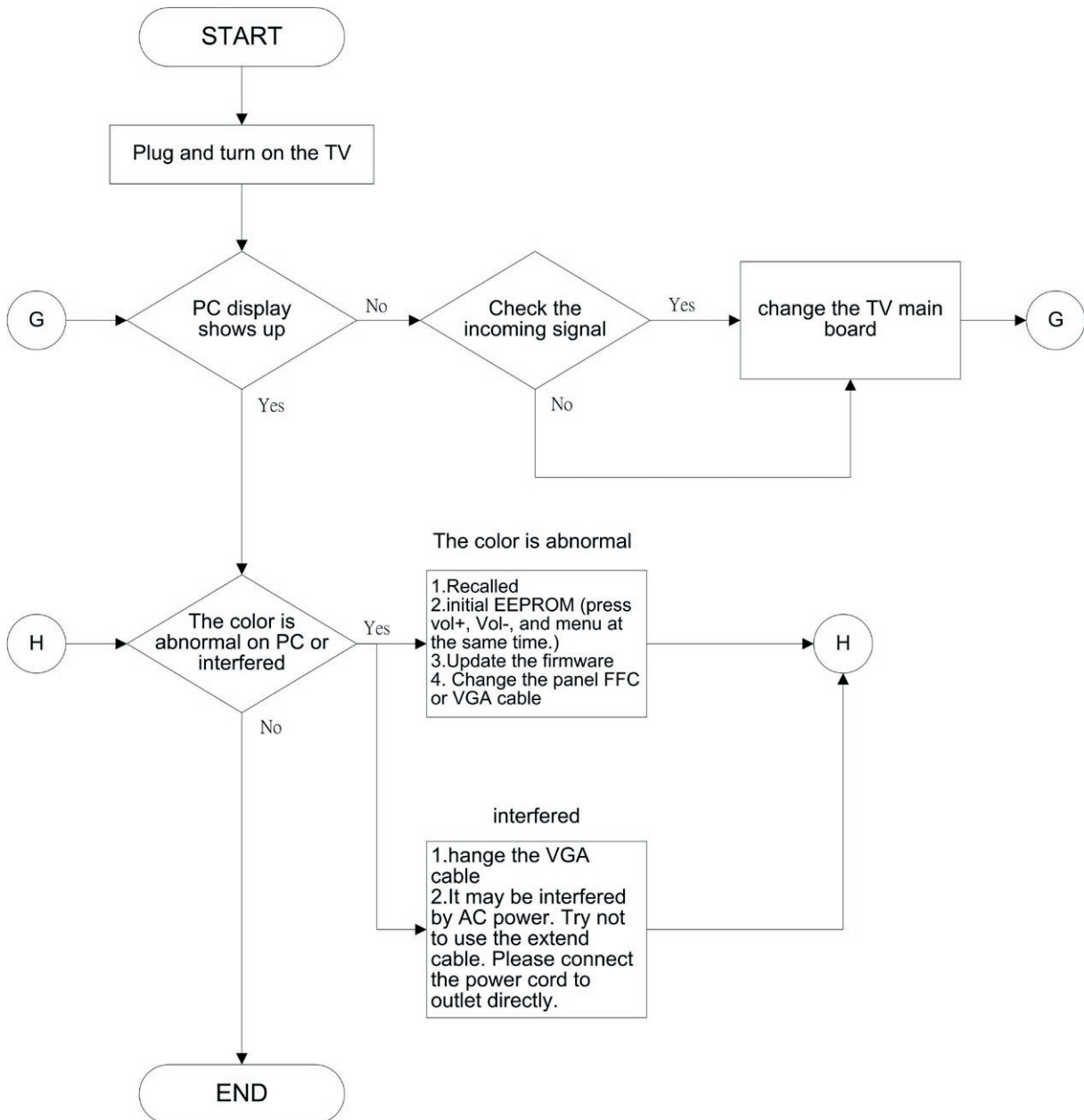

TV mode repair flowchart

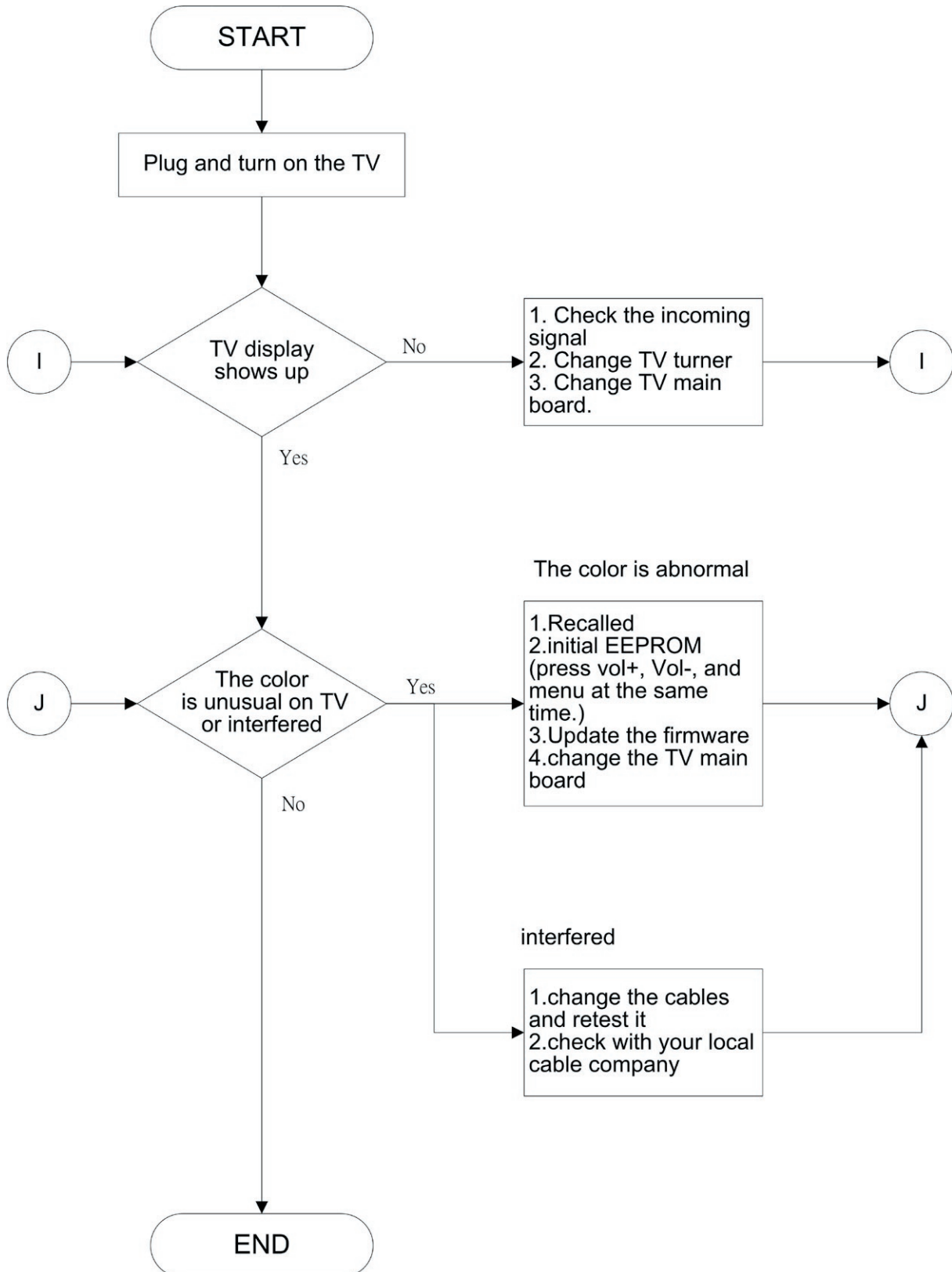

AV, SV & YcbCr mode repair flowchart

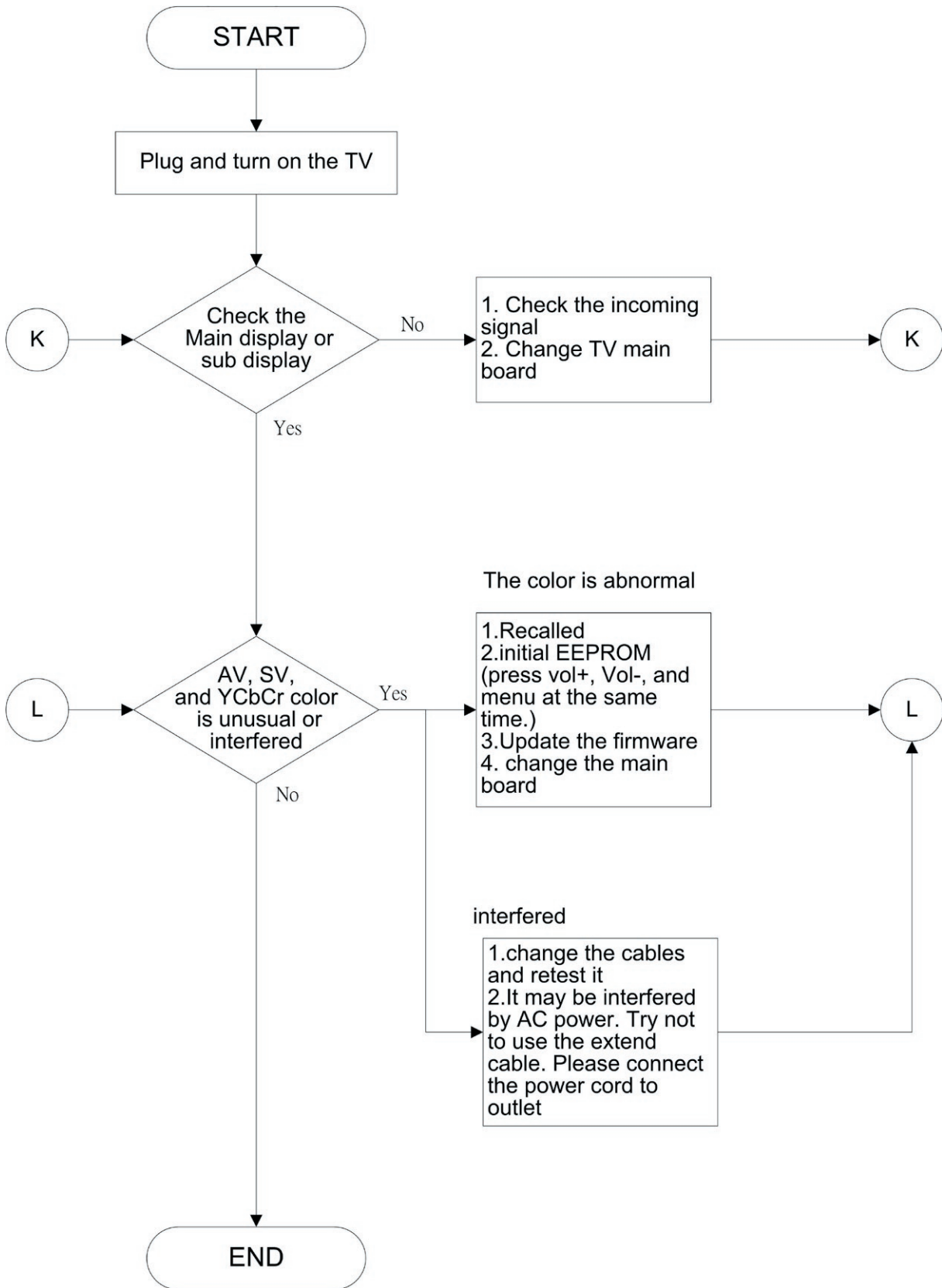

Audio repair flowchart

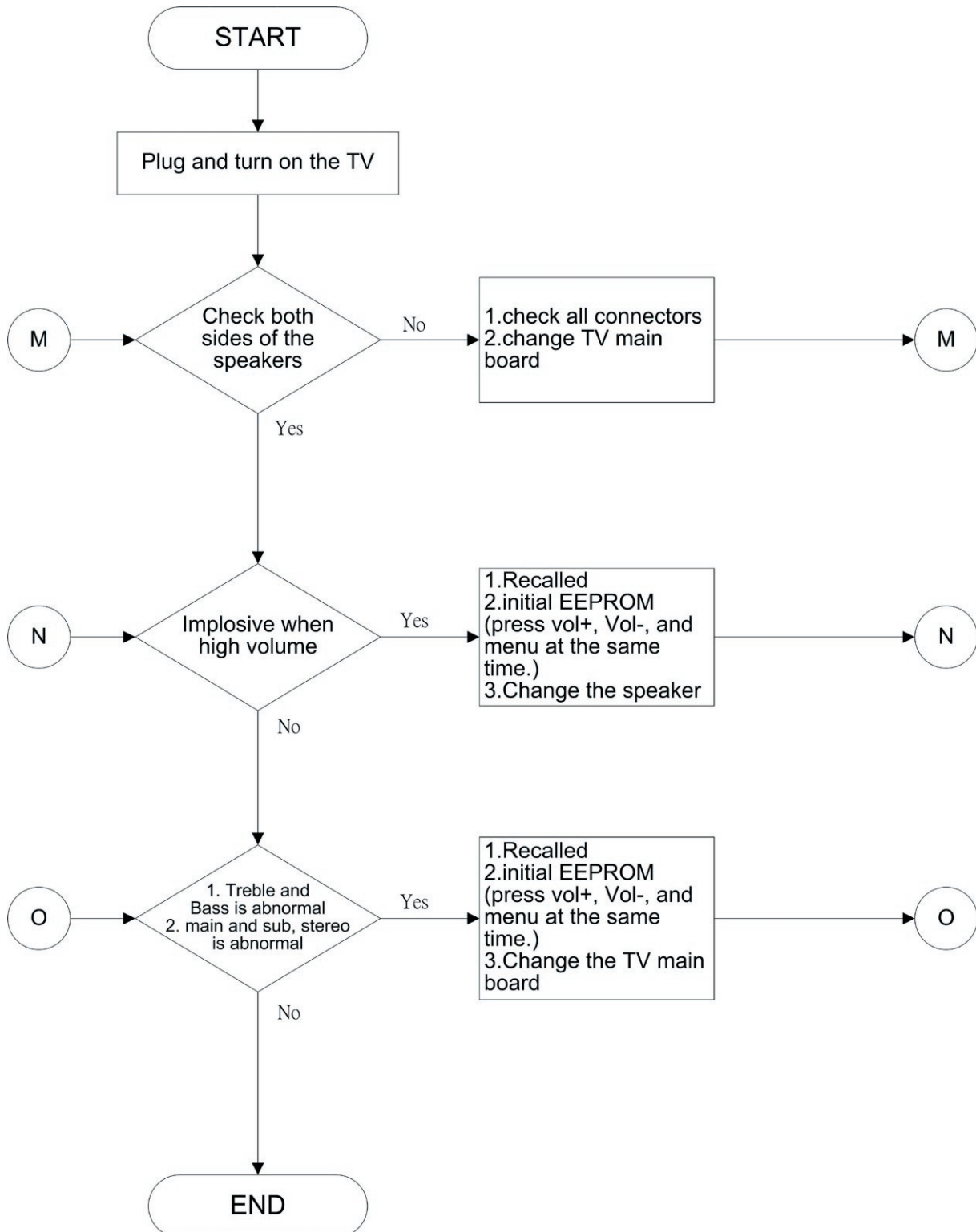

S.K.D.

| No. | Part no. | Parts Name | Q'ty | Position | Remark |
|-----|-------------|---|------|-------------|----------------------------|
| 1 | WA2109176 | FP1520 NTSC+V CHIP PCB | 1 | | |
| 2 | ZA2080002 | INVERTER PCB(QPWBGL945IDG) | 1 | | ECN-889 |
| 3 | WA2109051 | KEYPAD | 1 | | |
| 4 | WA2109050 | IR RECEIVER | 1 | | |
| 5 | VB1503251-1 | 15" PANEL (M150XN07) AU | 1 | | |
| 6 | JM0001211 | Cable, 5 PIN, P-P, 300mm | 1 | AP011206 | |
| 7 | JM0001311 | Cable, 5 PIN, P-P, 30mm | 1 | AP011208 | |
| 8 | AA1300920 | Power cover | 1 | AP020202(A) | |
| 9 | AA1301331 | LCD front cover | 1 | AP040804(A) | PANEL(plastic) ECN-916 |
| 10 | AA1302452 | LCD back cover | 1 | AP040819(B) | ECN-889,898 |
| 11 | AA1301350 | 4 KEY button | 1 | AP040805 | ECN-889,894 |
| 12 | AA1301360 | 2 KEY button | 1 | AP040806 | ECN-889,894 |
| 13 | AA1302480 | HDSP speaker fixer | 4 | AP040822(A) | ECN-889 |
| 14 | AA1301380 | Stand | 1 | AP040802 | Stand(plastic) |
| 15 | AA1302490 | HINGE left cover | 1 | AP040824(A) | ECN-889 |
| 16 | AA1302500 | HINGE right cover | 1 | AP040825(A) | ECN-889 |
| 17 | AA1302510 | FP2010 HINGE cover | 1 | AP040823(A) | ECN-889 |
| 18 | AB0700870 | IR LENS | 1 | AP020207 | |
| 19 | BR1935006 | LVDS cable, color white #30 350mm (with CORE) | 1 | AP040928 | ECN-925 |
| 20 | BZ0130020 | KEYPAD cable 10 PIN P-P 130mm(Unshield) | 1 | AP040816(A) | ECN-889,925 |
| 21 | EA0301211 | M3*6, P+3*6 ISO NI | 19 | | ECN-894 |
| 22 | EA0305111 | P+3*10 TP-3 BK | 6 | KEYPAD | ECN-894,904 |
| 23 | EA0302511 | P+3*12 TP-3 NI | 4 | | ECN-904 |
| 24 | EA0304811 | P+5*12 ISO BK | 4 | | |
| 25 | EA1500611 | M3*4, III+3*4 ISO NI | 2 | | |
| 26 | EA1502011 | Screws 3*10 BK | 8 | | |
| 27 | EA0304911 | P+3*6 ISO BK | 2 | | ECN-894 |
| 28 | EA0301511 | P+3*8 TP-3 NI | 4 | | ECN-894 |
| 29 | EC0300381 | M5 change to M4 Screws | 4 | AP040843 | ECN-907 |
| 30 | EC0500781 | DB15HD(VGA) screw 4#40*4.8 | 2 | | |
| 31 | EK0605011 | LCD metal board SECC FOR AU | 1 | AP040832 | |
| 32 | EK0605111 | EMI metal board SECC | 1 | AP040833 | |
| 33 | EK0605211 | Switch EMI metal board | 1 | AP040849 | ECN-909 |
| 34 | EK1401201 | VGA metal board SECC | 1 | AP020213 | |
| 35 | EK1401301 | Switch metal board SECC | 1 | AP040828 | |
| 36 | ER1300601 | HINGE | 1 | AP040829 | |
| 37 | WA1000128 | Left speaker | 1 | | |
| 38 | WA1000129 | Right speaker | 1 | | |
| 39 | MF4100019 | VGA Conductive Shielding Gasket 250*30*1mm | 1 | | |
| 40 | MF4100031 | Conductive Shielding Gasket (W)(14)*(H)5*(L)29mm | 1 | KEYPAD | ECN-889 |
| 41 | MF4100034 | Conductive Shielding Gasket (W)(12)*(H)11.5*(L)100mm | 3 | | ECN-889 |
| 42 | MG7400001 | Aluminum foil stickers W(15)*L(20)mm | 2 | EMI | AP040811(A) ECN-889,916 |
| 43 | MG7400002 | Aluminum foil stickers W(15)*L(30)mm | 2 | EMI | AP040812(A) ECN-889,916 |
| 44 | MG7400003 | Aluminum foil stickers W(10)*L(55)mm | 3 | EMI | AP040813 ECN-889 |
| 45 | MG7400004 | Aluminum foil stickers W(20)*L(330)mm | 2 | PANEL&LCD | AP040814 ECN-889 |
| 46 | MG7400005 | Aluminum foil stickers W(25)*L(205)*0.1mm | 1 | PANEL&LCD | ECN-925 |

| | | | | | |
|-----------|-----------|---|-----|------------------|-------------|
| 47 | MG7400006 | Aluminum foil stickers W(20)*L(160)*0.1mm | 1 | PANEL&LCD | ECN-925 |
| 48 | MG7400007 | Aluminum foil stickers W(15)*L(250)*0.1mm | 1 | Back cover & LCD | ECN-925,932 |
| 49 | MG7400008 | Aluminum foil stickers W(30)*L(70)*0.1mm | 1 | Back cover & LCD | ECN-925 |
| 50 | GG0000131 | Rubber stickers 19*4 | 5 | | |
| 51 | ZB2040028 | AC ADAPTER (OUT:12V 3A) | 1 | | |
| 52 | MG5700059 | Bar Code stickers 3/4*2 | 1 | AP040847 | ECN-909,911 |
| 53 | MF4300038 | EPE FORM Left | 1 | | ECN-894 |
| 54 | MF4300039 | EPE FORM Right | 1 | | ECN-894 |
| 55 | MF4300040 | EPE Bag | 1 | | |
| 56 | WA1300013 | Gift box half-finished product | 1 | | |
| customize | | | | | |
| 57 | Firmware | OSD | | | |
| 58 | ZB2010097 | FP1520 Remote Control | 1 | | |
| 59 | ZB1020064 | AC ADAPTER | 1 | AP011116 | |
| 60 | MA0100073 | Master carton 600*505*480mm | 1/2 | | ECN-898,911 |
| 61 | MB0200028 | Accessory box 340*191*45mm | 1 | AP030712 | ECN-898 |
| 62 | MG5307099 | Safety label | 1 | AP040836 | |
| 63 | MG5700060 | Gift box label | 1 | AP040848 | ECN-909 |
| 64 | MG5800113 | Badge | 1 | AP040837 | |
| 65 | MG5800117 | Hi-POT stickers | 1 | AP040835 | ECN-904 |
| 66 | MG5800119 | WARMING LABEL | 1 | AP040844 | ECN-907 |
| 67 | MI7100128 | FP1520 Manual | 1 | | |

i Contents

1.0 Handling Precautions

2.0 General Description

- 2.1 Display Characteristics
- 2.2 Functional Block Diagram

3.0 Absolute Maximum Ratings

4.0 Optical Characteristics

- 4.1 Signal for Lamp connector
- 4.2 Parameter guideline for CCFL Inverter

5.0 Signal Interface

- 5.1 Module Interface Connectors
- 5.2 Module Connector Pin Configuration
- 5.3 Backlight Connectors
- 5.4 Backlight Connector Pin Configuration
- 5.5 Signal Electrical Characteristics
- 5.6 Interface Timings Characteristics
- 5.7 Interface Timing Definition

6.0 Pixel format image

7.0 Power Consumption

8.0 Power ON/OFF Sequence

9.0 Backlight Characteristics

- 9.1 Signal for Lamp connector
- 9.2 Parameter guideline for CCFL Inverter

10.0 Vibration, Shock, and Drop

- 10.1 Vibration & Shock
 - 10.1.1 Vibration Test Spec
 - 10.1.2 Shock Test Spec
- 10.2 Drop

11.0 Environment

- 11.1 Temperature and Humidity
 - 11.1.1 Operating Conditions
 - 11.1.2 Shipping Conditions
- 11.2 Atmospheric Pressure
- 11.3 Thermal Shock

12.0 Reliability

- 12.1 Failure criteria
- 12.2 Failure rate
 - 12.2.1 Usage
 - 12.2.2 Components de-rating
- 12.3 CCFL life
- 12.4 ON/OFF cycle

(C) Copyright AU Optronics, Inc.

Feb. 2003 All Rights Reserved.

M150XN07 Ver0.1

3/28

No Reproduction and Redistribution Allowed.

13.0 Safety

- 13.1 Sharp edge requirement
- 13.2 Material
 - 13.2.1 Toxicity
 - 13.2.2 Flammability
- 13.3 Capacitors
- 13.4 Hazardous voltage

14.0 Other requirements

- 14.1 Smoke free design
- 14.2 National test lab requirement

15.0 Label

16.0 Mechanical Characteristics

ii Record of Revision

| Version and Date | Page | Old description | New Description | Remark |
|------------------|------|----------------------------|-----------------|--------|
| 0.1 2003/06/10 | All | First Edition for Customer | All | |
| | | | | |
| | | | | |
| | | | | |

1.0 Handling Precautions

- 1) Since front polarizer is easily damaged, pay attention not to scratch it.
- 2) Be sure to turn off power supply when inserting or disconnecting from input connector.
- 3) Wipe off water drop immediately. Long contact with water may cause discoloration or spots.
- 4) When the panel surface is soiled, wipe it with absorbent cotton or other soft cloth.
- 5) Since the panel is made of glass, it may break or crack if dropped or bumped on hard surface.
- 6) Since CMOS LSI is used in this module, take care of static electricity and insure human earth when handling.
- 7) Do not open nor modify the Module Assembly.
- 8) Do not press the reflector sheet at the back of the module to any directions.
- 9) In case if a Module has to be put back into the packing container slot after once it was taken out from the container, do not press the center of the CCFL Reflector edge. Instead, press at the far ends of the CFL Reflector edge softly. Otherwise the TFT Module may be damaged.
- 10) At the insertion or removal of the Signal Interface Connector, be sure not to rotate nor tilt the Interface Connector of the TFT Module.
- 11) After installation of the TFT Module into an enclosure (LCD monitor housing, for example), do not twist nor bend the TFT Module even momentary. At designing the enclosure, it should be taken into consideration that no bending/twisting forces are applied to the TFT Module from outside. Otherwise the TFT Module may be damaged.
- 12) Cold cathode fluorescent lamp in LCD contains a small amount of mercury. Please follow local ordinances or regulations for disposal.
- 13) Small amount of materials having no flammability grade is used in the LCD module. The LCD module should be supplied by power complied with requirements of Limited Power Source (2.11, IEC60950 or UL1950), or be applied exemption.
- 14) The LCD module is designed so that the CFL in it is supplied by Limited Current Circuit (2.4, IEC60950 or UL1950). Do not connect the CFL in Hazardous Voltage Circuit.

2.0 General Description

This specification applies to the 15.0 inch Color TFT-LCD Module M150XN07.

The display supports the XGA (1024(H) x 768(V)) screen format and 262,144 colors (RGB 6-bits data).

All input signals are 1 Channel LVDS interface compatible.

This module does not contain an inverter card for backlight.

Features

- XGA 1024(H) x 768(V) resolution
- 2 CCFLs (Cold cathode Fluorescent Lamp)
- High contrast ratio, high aperture ratio
- Wide viewing angle
- High-speed response
- Low power consumption

Application

Desktop monitors

2.1 Display Characteristics

The following items are characteristics summary on the table under 25 °C condition:

| ITEMS | Unit | SPECIFICATIONS |
|---|----------------------|--|
| Screen diagonal | [mm] | 381 (15") |
| Outline dimension | [mm] | 326.5 x 253.5 x 12.0 typ. |
| Display Area | [mm] | 304.128 (H) x 228.096(38.1cm diagonal) |
| Resolution | | 1024(R,G,B x 3) x 768 |
| Pixel Pitch | [mm] | 0.297 x 0.297 |
| Pixel Arrangement | | R.G.B. Vertical Stripe |
| Display Mode | | TN mode, Normally White |
| Typical white Luminance. | [cd/m ²] | 250nit (typ) @8mA (note 1) |
| Brightness uniformity | | 80% typ. (note 2) |
| Luminance uniformity | | 1.7 max.(Note 3) |
| Crosstalk (at 60Hz) | | 1.2% max. (note 4) |
| Contrast Ratio | | 400 : 1 typ. |
| Support Colors | | 262,144 colors (6-bit for R,G,B) |
| Chromaticity(CIE1931) | | 0.313 |
| White-x | | |
| White-y | | 0.329 |
| Color Gamut | | 60% typ., of NTSC coverage |
| Viewing angle | | 60(left),60(right),40(up),60(down) CR=10 |
| Response Time | [msec] | 16ms typ. (Tr +Tf) |
| Nominal Input Voltage VDD | [Volt] | +3.3 V |
| Power Consumption (VDD line + CCFL line) | [Watt] | 15 (typ.) @8mA (All Black Pattern) |
| Electrical Interface | | LVDS (1 ch) |
| Frame rate | [Hz] | 60Hz typ., 75Hz max. |
| Weight | [Grams] | 1100 typ. |
| Mounting method | | Side mounting |
| Surface treatment | | Anti-glare, hard coating (3H) |
| Temperature Range | | |
| Operating | [°C] | 0 to +50 |
| Storage (Shipping) | [°C] | -20 to +60 |

(C) Copyright AU Optronics, Inc.

Feb. 2003 All Rights Reserved.

M150XN07 Ver0.1

6/28

No Reproduction and Redistribution Allowed.

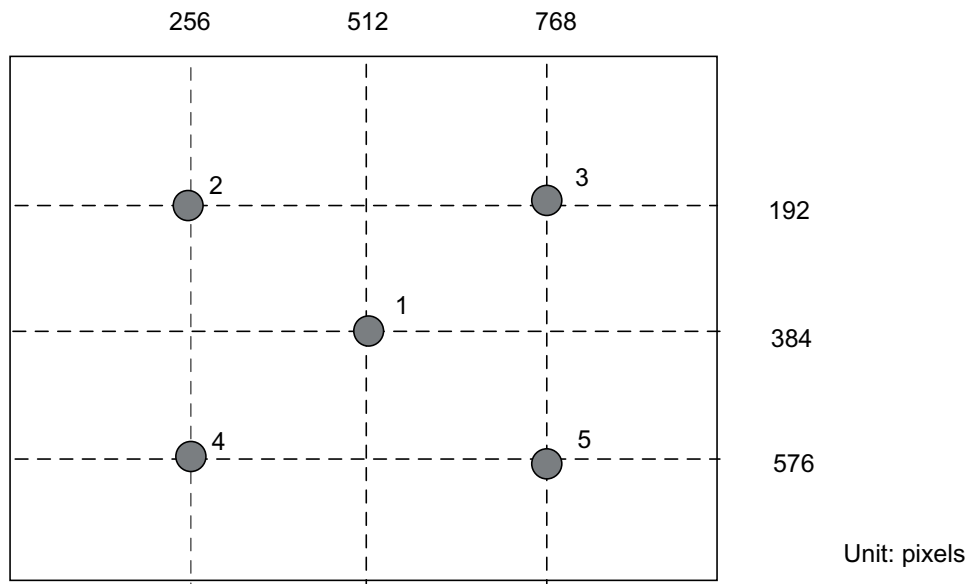

Note 1: Brightness is measured at the center point of brightness value with all pixels displaying white.

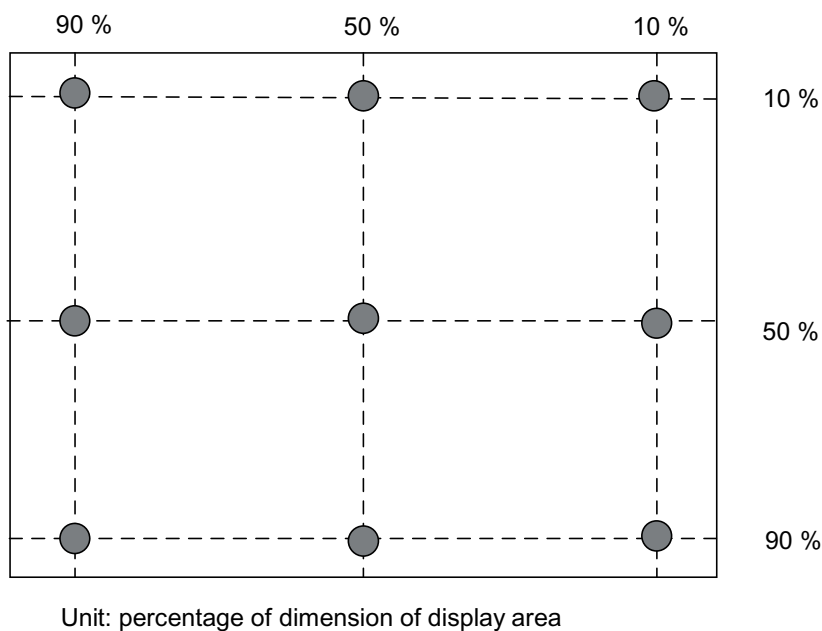

Note 2: Brightness uniformity of these 9 points is defined as below:

$$\left(\frac{\text{Min. brightness}}{\text{Max. brightness}} \right) \times 100\%$$

Note 3: TCO '99 Certification Requirements and test methods for environmental labeling of Display Report No. 2 defines Luminance uniformity as below:

$$\left(\frac{L_{\text{max},+30\text{deg.}}}{L_{\text{min},+30\text{deg.}}} + \frac{L_{\text{max},-30\text{deg.}}}{L_{\text{min},-30\text{deg.}}} \right) / 2$$

TCO 99 certification requirements and test methods

1) Diagrammatic :

(C) Copyright AU Optronics, Inc.

Feb. 2003 All Rights Reserved.

M150XN07

Ver0.1

7/28

No Reproduction and Redistribution Allowed.

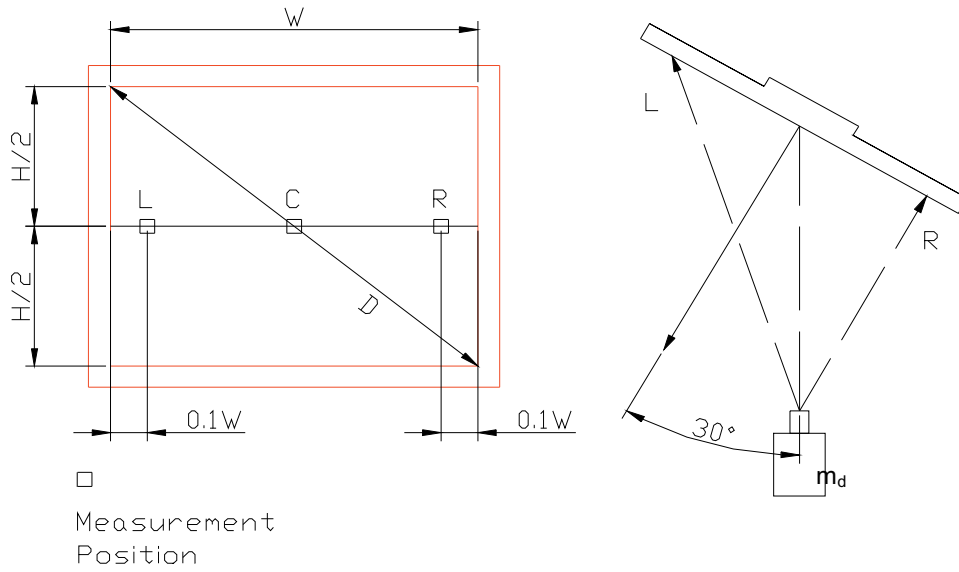

□
Measurement
Position

Effective area : $W \times H$

$L_{\max} \cdot +30^\circ$ and $L_{\min} \cdot +30^\circ$

2) D is the diagonal of the screen in centimeters. And m_d is as follow.

$$m_d(\text{cm}) = D \times 1.5 \text{ with a minimum distance : } m_d = 50 \text{ cm}$$

3) The measurement positions shall consist of an active white square of size 4 by 4 cm.

4) Measure $L_{\max} \cdot +30^\circ$ and $L_{\min} \cdot +30^\circ$ that are given as points L & R. And then rotated to an azimuth angle of -30° degrees and measure $L_{\max} \cdot -30^\circ$ and $L_{\min} \cdot -30^\circ$ again using the same procedure.

5) The variation in luminance ratio is calculated as the ratio:

$$L_R = ((L_{\max} \cdot +30^\circ / L_{\min} \cdot +30^\circ) + (L_{\max} \cdot -30^\circ / L_{\min} \cdot -30^\circ)) / 2 \leq \mathbf{1.7}$$

Note 4:

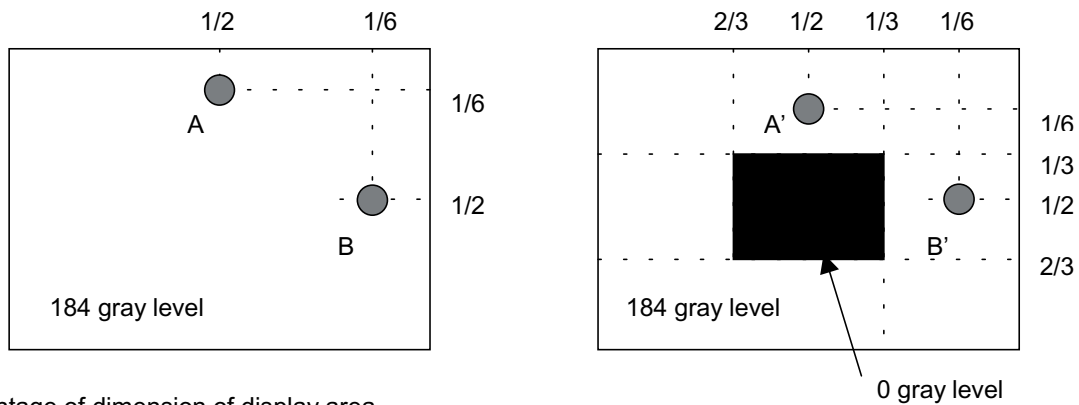

Unit: percentage of dimension of display area

$$|L_A - L_{A'}| / L_A \times 100\% = 1.2\% \text{ max., } L_A \text{ and } L_B \text{ are brightness at location A and B}$$

$$|L_B - L_{B'}| / L_B \times 100\% = 1.2\% \text{ max., } L_{A'} \text{ and } L_{B'} \text{ are brightness at location A' and B'}$$

(C) Copyright AU Optronics, Inc.

Feb. 2003 All Rights Reserved.

M150XN07

Ver0.1

8/28

No Reproduction and Redistribution Allowed.

2.2 Functional Block Diagram

The following diagram shows the functional block of 15.0 inches Color TFT-LCD Module:

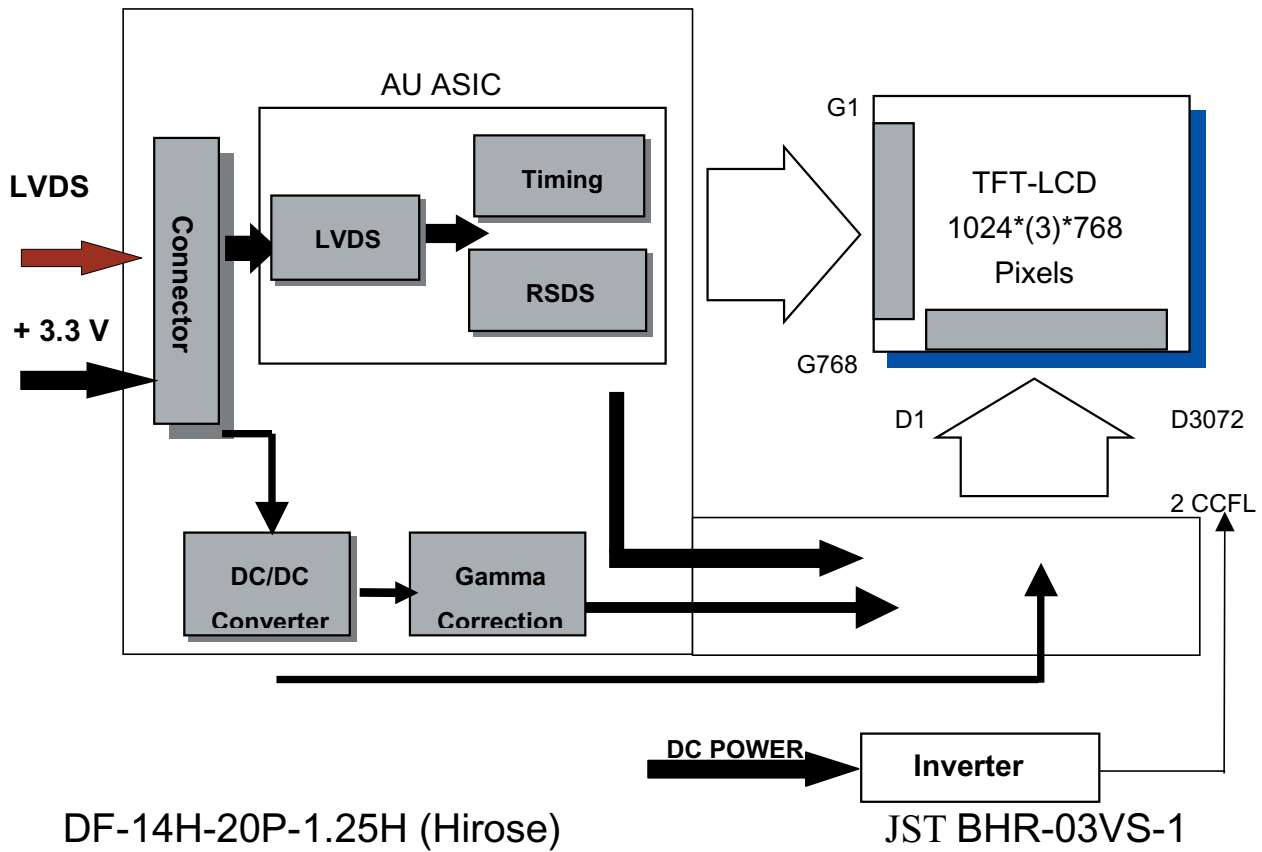

(C) Copyright AU Optronics, Inc.

Feb. 2003 All Rights Reserved.

No Reproduction and Redistribution Allowed.

M150XN07

Ver0.1

9/28

3.0 Absolute Maximum Ratings

Absolute maximum ratings of the module is as following:

| Item | Symbol | Min | Max | Unit | Conditions |
|------------------------------|--------|------|--------------|----------|----------------|
| Logic/LCD Drive Voltage | VDD | -0.3 | +3.6 | [Volt] | |
| Input Voltage of Signal | Vin | -0.3 | VDD+0.3 | [Volt] | |
| CCFL Current | ICFL | 3.0 | 9.0 | [mA] rms | Note 1 |
| Operating Temperature | TOP | 0 | +50 | [°C] | Note 2 |
| Operating Humidity | HOP | 20 | 85 | [%RH] | Note 2 |
| Storage Temperature | TST | -20 | +60 | [°C] | Note 2 |
| Storage Humidity | HST | 5 | 95 | [%RH] | Note 2 |
| Vibration | | | 1.5 / 10-200 | [G / Hz] | |
| Shock | | | 50/20 | [G / ms] | Half sine wave |
| Assured Torque at Side Mount | | | 2.0 | [kgf.cm] | |
| Re-screw | | | 3 | [Times] | |

Note 1: To exceed 8.0mA, life time accelerate drop down and if to exceed 9.0mA has safety problem

Note 2 : Maximum Wet-Bulb should be 39°C and No condensation.

Wet bulb temperature chart

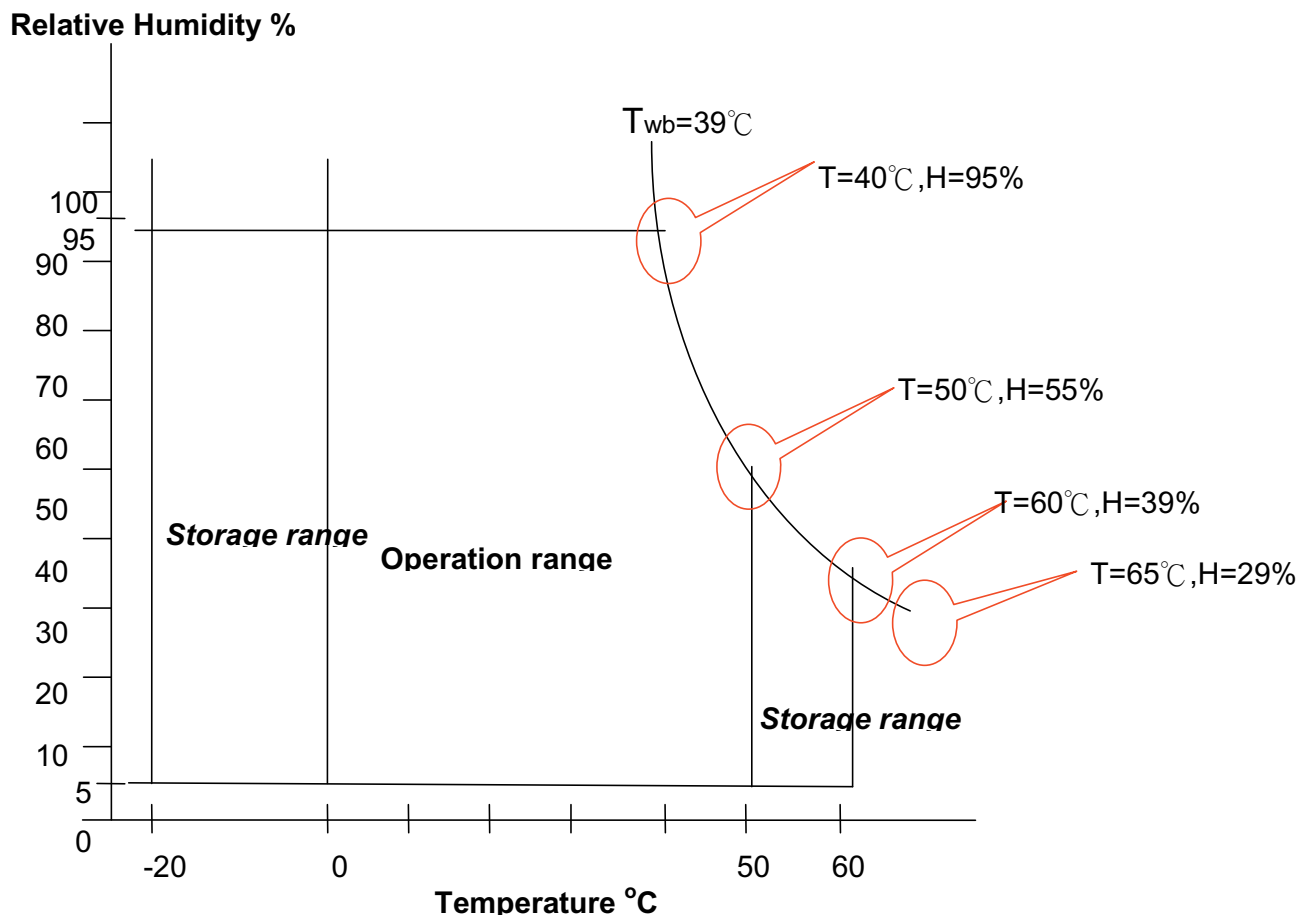

4.0 Optical Characteristics

The optical characteristics are measured under stable conditions at 25°C (Room Temperature):

| Item | Unit | Conditions | Min. | Typ. | Max. |
|--|----------------------|-------------------------------|-------|-------|-------|
| Viewing Angle | [degree] | Horizontal (Right) | 50 | 60 | |
| | | CR = 10 (Left) | 50 | 60 | |
| | [degree] | Horizontal (Right) | 60 | 75 | |
| | | CR =5 (Left) | 60 | 75 | |
| CR: Contrast Ratio | [degree] | Vertical (Upper) | 30 | 40 | |
| | | CR = 10 (Lower) | 50 | 60 | |
| | [degree] | Vertical (Upper) | 60 | 70 | |
| | | CR = 5 (Lower) | 65 | 75 | |
| Contrast ratio | | Normal Direction | 300 | 400 | - |
| Response Time(Note 1) | [msec] | Raising Time Ton (10%-90%) | - | 4 | 6 |
| | [msec] | Falling Time Toff (90%-10%) | - | 12 | 17 |
| | [msec] | Raising + Falling | - | 16 | 23 |
| Color / Chromaticity Coordinates (CIE) | | Red x | 0.587 | 0.617 | 0.647 |
| | | Red y | 0.317 | 0.347 | 0.377 |
| | | Green x | 0.260 | 0.290 | 0.320 |
| | | Green y | 0.563 | 0.593 | 0.623 |
| | | Blue x | 0.118 | 0.148 | 0.178 |
| | | Blue y | 0.070 | 0.100 | 0.130 |
| Color Coordinates (CIE) White | | White x | 0.283 | 0.313 | 0.343 |
| | | White y | 0.299 | 0.329 | 0.359 |
| Brightness Uniformity | [%] | | 75 | 80 | - |
| White Luminance at CCFL 8.0mA | [cd/m ²] | | 200 | 250 | - |
| White Luminance at CCFL 6.5mA | | | 170 | 200 | - |
| Crosstalk (in 60Hz) | [%] | | | | 1.2 |

Note 1: Definition of Response time:

The output signals of photodetector are measured when the input signals are changed from “Black” to “White” (falling time), and from “White” to “Black” (rising time), respectively. The response time interval between the 10% and 90% of amplitudes. Refer to figure as below.

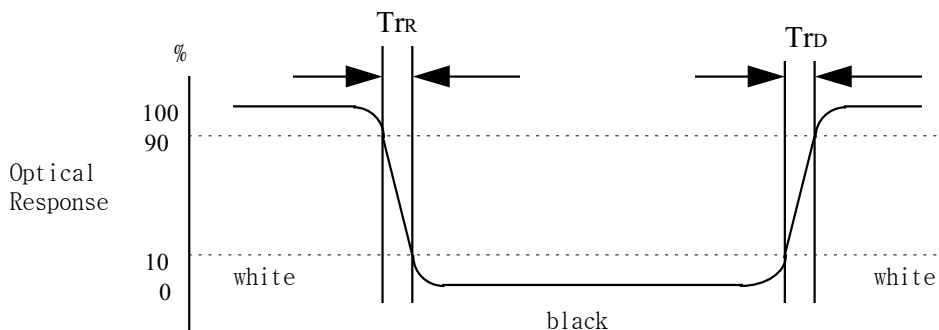

(C) Copyright AU Optronics, Inc.

Feb. 2003 All Rights Reserved.

M150XN07 Ver0.1

11/28

No Reproduction and Redistribution Allowed.

5.0 Signal Interface

5.1 Module Interface Connectors

Physical interface is described as for the connector on module.

These connectors are capable of accommodating the following signals and will be following components

| | |
|---------------------------|--|
| Connector Name | Interface Connector |
| Manufacturer | Hirose, PTWO or compatible |
| Type / Part Number | DF-14H-20P-1.25H (Hirose) CWY20G-A0D1T (PTWO) |

5.2 Module Connector Pin Configuration

| DF-14H-20P-1.25H (Hirose) or CWY20G-A0D1T (PTWO) | | |
|--|--------|--|
| Pin No. | Symbol | Description |
| 1 | VDD | Power Supply, 3.3V (typical) |
| 2 | VDD | Power Supply, 3.3V (typical) |
| 3 | VSS | Ground |
| 4 | VSS | Ground |
| 5 | Rin0- | - LVDS differential data input (R0-R5, G0) |
| 6 | Rin0+ | + LVDS differential data input (R0-R5, G0) |
| 7 | VSS | Ground |
| 8 | Rin1- | - LVDS differential data input (G1-G5, B0-B1) |
| 9 | Rin1+ | + LVDS differential data input (G1-G5, B0-B1) |
| 10 | VSS | Ground |
| 11 | Rin2- | - LVDS differential data input (B2-B5, HS, VS, DE) |
| 12 | Rin2+ | + LVDS differential data input (B2-B5, HS, VS, DE) |
| 13 | VSS | Ground |
| 14 | ClkIN- | - LVDS differential clock input |
| 15 | ClkIN+ | + LVDS differential clock input |
| 16 | VSS | Ground |
| 17 | Rin3- | NC |
| 18 | Rin3+ | NC |
| 19 | VSS | Ground |
| 20 | NC | Reserved |

5.3 Backlight Connectors

| | |
|-------------------------------------|---------------------|
| Connector Name / Designation | For Lamp Connector |
| Manufacturer | JST or compatible |
| Type / Part Number | BHR-03VS-1 |
| Mating Type / Part Number | SM02(8.0)B-BHS-1-TB |

5.4 Backlight Connector Pin Configuration

| Pin | Symbol | Description |
|-----|--------|-------------------|
| 1 | HV | Lamp High Voltage |
| 2 | NC | No connection |
| 3 | LV | Ground |

- ◆ Cable length: 140 +/- 5 mm
- ◆ Connector-output position: right side (front view)
- ◆ Lamp assy design shall be easy for replacement and repair.

5.5 Signal Electrical Characteristics

Each signal characteristics are as follows;

| Item | Symbol | Min | Typ | Max | Unit |
|-----------------------------|--------|------|------|------|------|
| LCD Drive voltage | VDD | +3.0 | +3.3 | +3.6 | [V] |
| “High” input signal voltage | Vih | 2.0 | - | - | [V] |
| “Low” input signal voltage | Vil | - | - | 0.8 | [V] |

6bits input data format

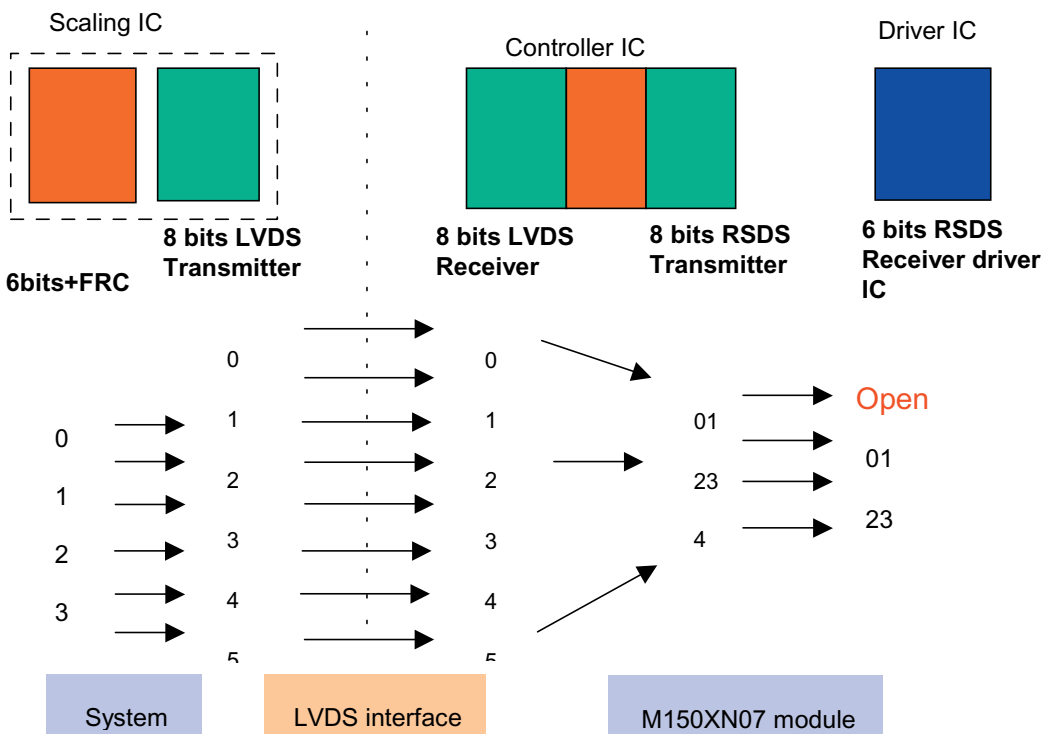
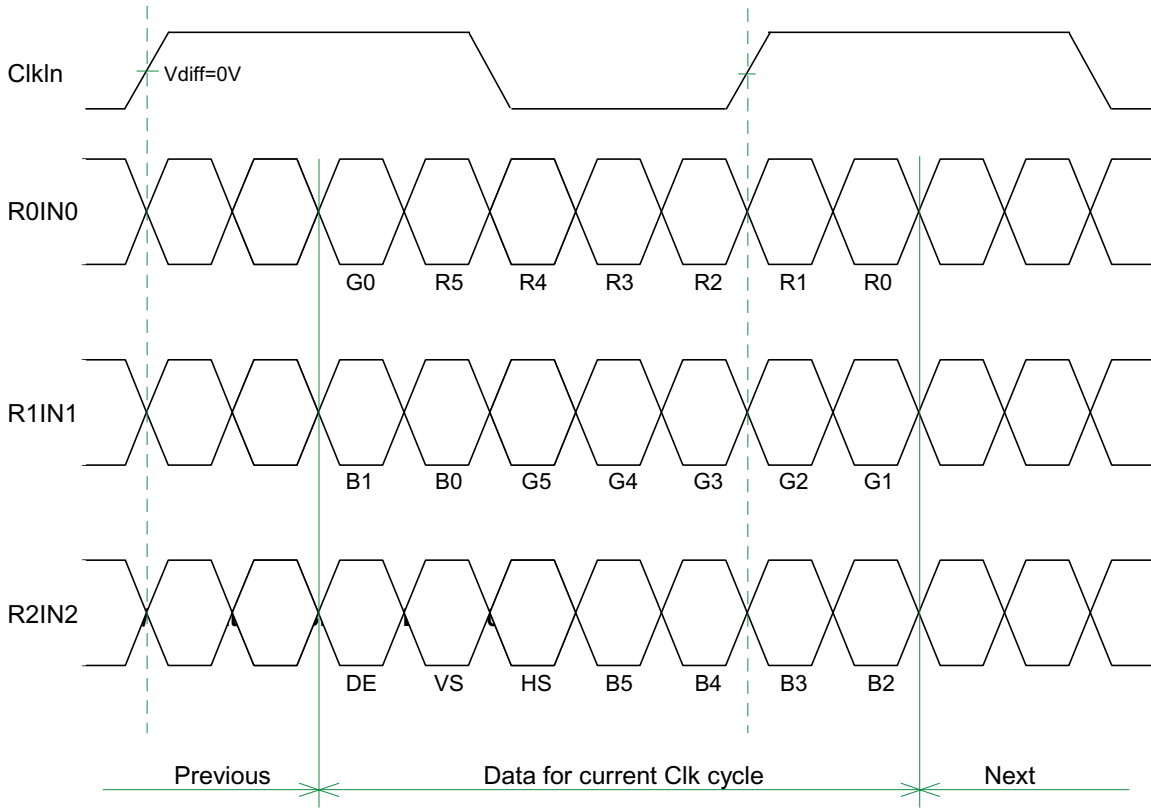

(C) Copyright AU Optronics, Inc.

Feb. 2003 All Rights Reserved.

No Reproduction and Redistribution Allowed.

M150XN07

Ver0.1

14/28

6bits input data format

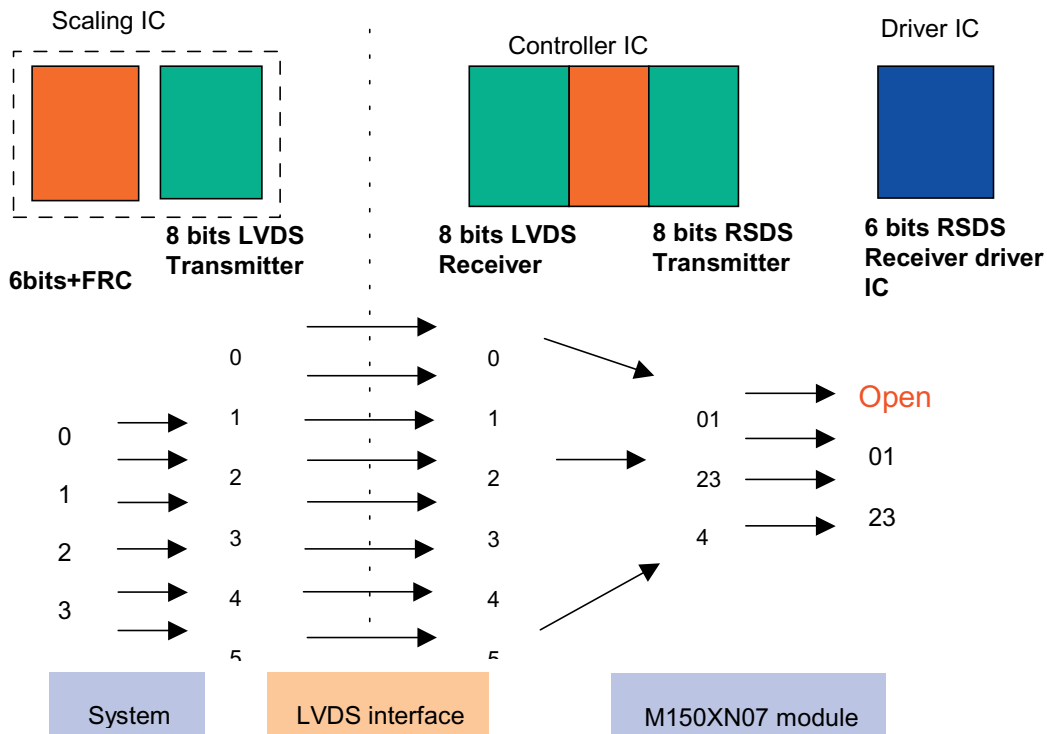
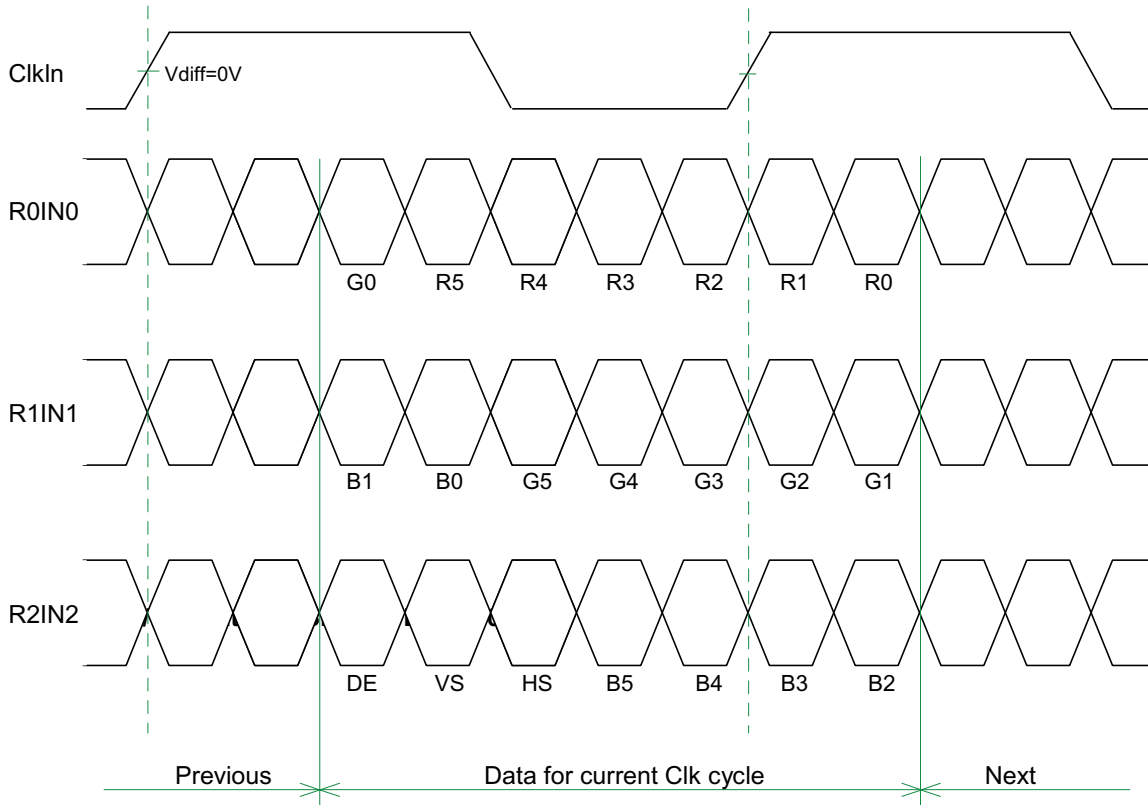

(C) Copyright AU Optronics, Inc.

Feb. 2003 All Rights Reserved.

No Reproduction and Redistribution Allowed.

M150XN07

Ver0.1

14/28

References

5.6 Signal Electrical Characteristics

Input signals shall be low or Hi-Z state when Vin is off

It is recommended to refer the specifications of SN75LVDS82DGG (Texas Instruments) in detail.

Each signal characteristics are as follows;

| Parameter | Condition | Min | Max | Unit |
|-----------|--|------|-----|------|
| Vth | Differential Input High Voltage(Vcm=+1.2V) | | 100 | [mV] |
| Vtl | Differential Input Low Voltage(Vcm=+1.2V) | -100 | | [mV] |

5.7 Interface Timings

Basically, interface timings described here is not actual input timing of LCD module but output timing of SN75LVDS82DGG (Texas Instruments) or equivalent.

5.7.1 Timing Characteristics

| Signal | Item | Symbol | MIN | TYP | MAX | Unit |
|---------|----------------|---------|-------|------|-----|-------|
| DTCLK | Freq. | Fdck | | 65 | 81 | MHz |
| DTCLK | Cycle | Tck | 12.3 | 15.4 | | ns |
| +V-Sync | Frame Rate | 1/Tv | | 60 | 75 | Hz |
| +V-Sync | Cycle | Tv | 13.33 | 16.7 | | ms |
| +V-Sync | Cycle | Tv | | 806 | | lines |
| +V-Sync | Active level | Tva | | 6 | | lines |
| +V-Sync | V-back porch | Tvb | | 29 | | lines |
| +V-Sync | V-front porch | Tvf | | 3 | | lines |
| +DSPTMG | V-Line | M | | 768 | | lines |
| +H-Sync | Scan rate | 1/Th | | 60 | | KHz |
| +H-Sync | Cycle | Th | | 1344 | | Tck |
| +H-Sync | Active level | Tha(*1) | | 136 | | Tck |
| +H-Sync | Back porch | Thb(*1) | | 160 | | Tck |
| +H-Sync | Front porch | Thf | | 24 | | Tck |
| +DSPTMG | Display Pixels | N | | 1024 | | Tck |

Note: Typical value refer to VESA STANDARD

5.8 Interface Timing Definition

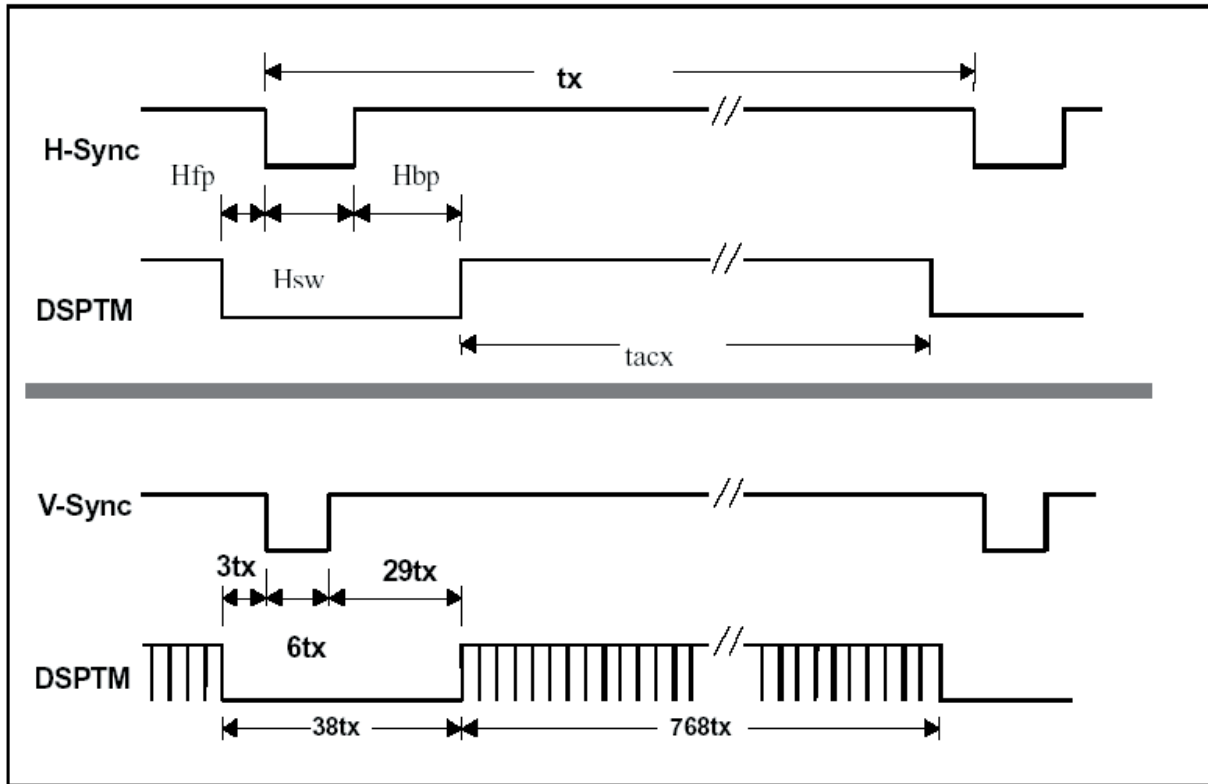

(C) Copyright AU Optronics, Inc.

Feb. 2003 All Rights Reserved.

No Reproduction and Redistribution Allowed.

M150XN07

Ver0.1

16/28

6.0 Pixel format image

Following figure shows the relationship of the input signals and LCD pixel format.

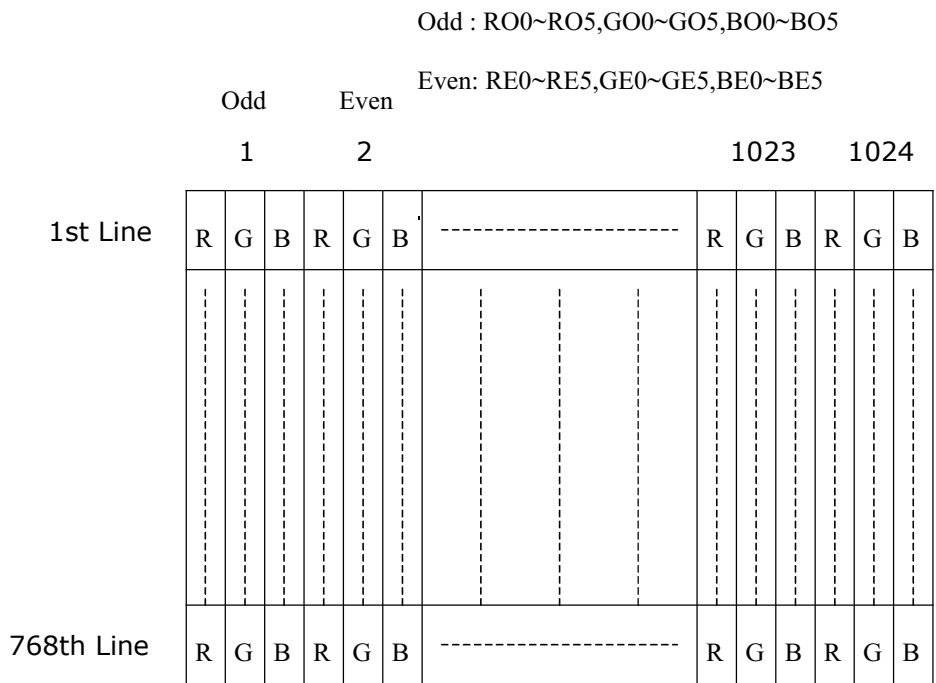

7.0 Power Consumption

Input power specifications are as follows;

| Symbol | Parameter | Min | Typ | Max | Units | Condition |
|--------|----------------------------------|-----|------|------|-------------|-----------------------------|
| VDD | LCD Drive Voltage | 3.0 | 3.3 | 3.6 | [V] | |
| IDD | LCD Drive Current | - | 1200 | 1500 | [mA] | VDD=3.3v, All Black Pattern |
| PDD | LCD Drive power consumption | - | 4.5 | 5 | [Watt] | VDD=3.3v, All Black Pattern |
| VDDns | Allowable LCD Drive Ripple Noise | | | 100 | [mV] p-p | |

8.0 Power ON/OFF Sequence

VDD power and lamp on/off sequence is as follows. Interface signals are also shown in the chart.

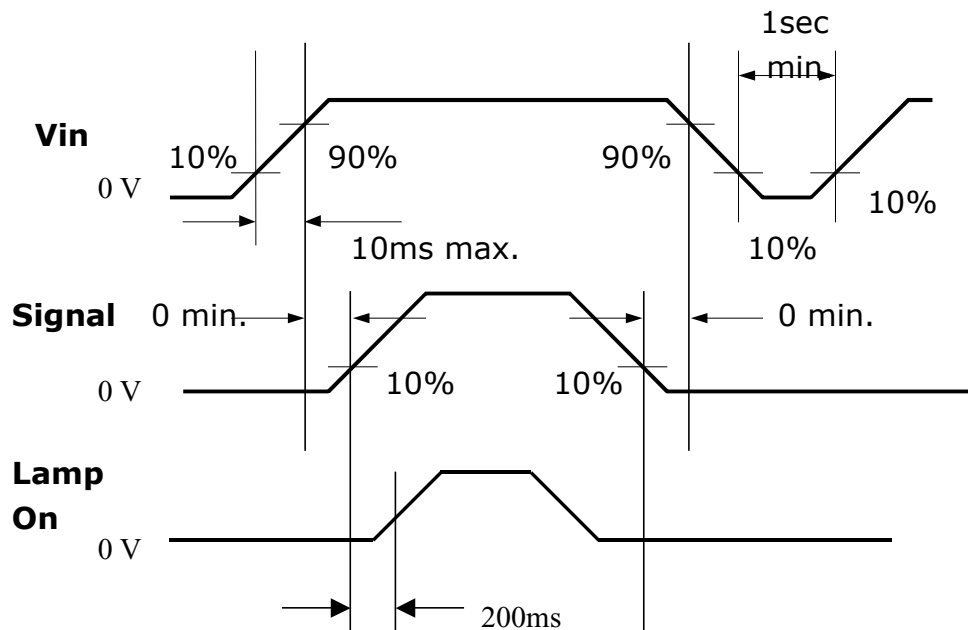

9.0 Backlight Characteristics

9.1 Signal for Lamp connector

| Pin # | signal Name |
|-------|-------------------|
| 1 | Lamp High Voltage |
| 2 | No connection |
| 3 | Ground |

9.2 Parameter guide line for CCFL Inverter

| Symble | Parameter | Min | Typ | Max | Units | Condition |
|--------------------------------|---|------|-----|------|---------------|-----------------------------|
| IRCFL | CCFL operation range | 3.0 | 8.0 | 8.5 | [mA] rms | (Ta=25°C) Note 4 |
| ICFL | CCFL Inrush current | - | - | 20 | [mA] | |
| FCFL | CCFL Frequency | 40 | 55 | 80 | [KHz] | (Ta=25°C) Note 1 |
| ViCFL (25°C) (reference) | CCFL Ignition Voltage | 1000 | | | [Volt] rms | (Ta= 25°C) Note 3 |
| ViCFL (0°C) (reference) | CCFL Ignition Voltage | 1300 | | | [Volt] rms | (Ta= 0°C) Note 3 |
| VCFL | CCFL Discharge Voltage (Reference) | | 590 | 650 | [Volt] rms | (Ta=25°C) Note 2 |
| PCFL | CCFL Power consumption @ 8mA (excluding inverter) | | 9.4 | 10.4 | [Watt] | (Ta=25°C) Note 2 |

Note 1: CCFL Frequency should be carefully determined to avoid interference between inverter and TFT LCD

Note 2: Calculator value for reference ($IRCFL \times VCFL \times 2 = PCFL$)

Note 3: CCFL inverter should be able to give out a power that has a generating capacity of over 1300 voltage.
Lamp units need 1300 voltage minimum for ignition

Note 4: CCFL life time 30,000hr at 8mA, it's defined as when the brightness is reduced by half.

To exceed 8.0mA, life time will drop down dramatically.

10.0 Vibration, Shock, and Drop

10.1 Vibration & Shock

The module shall work error free after following vibration and shock condition. Likewise the module shall not sustain any damage after vibration and shock test.

10.1.1 Vibration Test Spec:

- Frequency: 10 - 200Hz
- Sweep: 30 Minutes each Axis (X, Y, Z)
- Acceleration: 1.5G(10~200Hz P- P)
- Test method:

| | |
|--------------------------|-----------|
| Acceleration (G) | 1.5 |
| Frequency (Hz) | 10~200~10 |
| Active time (min) | 30 |

10.1.2 Shock Test Spec:

| | |
|-------------------------|----------|
| Acceleration (G) | 50 |
| Active time(ms) | 20 |
| Wave form | Half-sin |
| Times | 1 |

- Direction: $\pm X$, $\pm Y$, $\pm Z$

10.2 Drop

Package test: The drop height is defined as 60 cm.

(1 corner, 3 edges, 6 flat faces)
-- No damage and defect found for panel.

11.0 Environment

The display module will meet the provision of this specification during operating condition or after storage or shipment condition specified below. Operation at 10% beyond the specified range will not cause physical damage to the unit.

11.1 Temperature and Humidity

11.1.1 Operating Conditions

The display module operates error free, when operated under the following conditions;

| | |
|----------------------|---------------|
| Temperature | 0 °C to 50 °C |
| Relative Humidity | 20% to 85% |
| Wet Bulb Temperature | 39.0 °C |

11.1.2 Shipping Conditions

The display module operates error free, after the following conditions;

| | |
|----------------------|-----------------|
| Temperature | -20 °C to 60 °C |
| Relative Humidity | 5% to 95% |
| Wet Bulb Temperature | 39.0 °C |

11.2 Atmospheric Pressure

The display assembly is capable of being operated without affecting its operations over the pressure range as following specified:

| | Pressure | Altitude |
|------------------|----------|----------------------|
| Maximum Pressure | 1040 hPa | 0 m = sea level |
| Minimum Pressure | 601 hPa | 3658 m = 12,000 feet |

Note: Non-operation altitude limit of this display module = 40,000 feet. = 12193 m.

11.3 Thermal Shock

The display module will not sustain damage after being subjected to 100 cycles of rapid temperature change. A cycle of rapid temperature change consists of varying the temperature from -20°C to 60°C, and back again.

| | |
|----------------------------|-------------------------------------|
| Thermal shock cycle | -20 °C for 30min 60 °C for 30min |
|----------------------------|-------------------------------------|

Power is not applied during the test. After temperature cycling, the unit is placed in normal room ambient for at least 4 hours before powering on.

12.0 Reliability

This display module and the packaging of that will comply following standards.

12.1 Failure Criteria

The display assembly will be considered as failing unit when it no longer meets any of the requirements stated in this specification. Only as for maximum white luminance, following criteria is applicable.

- **Maximum white Luminance shall be 75 cd/m² or more.**

12.2 Failure Rate

The average failure rate of the display module (from first power-on cycle till 1,000 hours later) will not exceed 1.0%. The average failure rate of the display module from 1,000 hours until 10,000 hours will not exceed 0.70% per 1000 hours.

12.2.1 Usage

The assumed usage for the above criteria is:

- 220 power-on hours per month
- 500 power on/off cycles per month
- Maximum brightness setting
- Operation to be within office environment (25°C typical)

12.2.2 Component De-rating

All the components used in this device will be checked the load condition to meet the failure rate criteria.

12.3 CCFL Life

The assumed CCFL Life will be longer than 30,000 hours under stable condition at 25±5 °C;
Standard current at 8.0 ±0.5 mA

Definition of life: brightness becomes 50% or less than the minimum luminance value of CCFL.

12.4 ON/OFF Cycle

The display module will be capable of being operated over the following ON/OFF Cycles.

| ON/OFF | Value | Cycle |
|---------------------|--------|--------------------------------|
| +VDD and CCFL power | 36,000 | 10 seconds on / 10 seconds off |

13.0 Safety

13.1 Sharp Edge Requirements

There will be no sharp edges or corners on the display assembly that could cause injury.

13.2 Materials

13.2.1 Toxicity

There will be no carcinogenic materials used anywhere in the display module. If toxic materials are used, they will be reviewed and approved by the responsible AUO Toxicologist.

13.2.2 Flammability

All components including electrical components that do not meet the flammability grade UL94-V1 in the module will complete the flammability rating exception approval process. The printed circuit board will be made from material rated 94-V1 or better. The actual UL flammability rating will be printed on the printed circuit board.

14.0 Other requirements

14.1 Smoke Free Design

Any smoke nor strange smell shall not be observed by the operator at any single failure.

14.2 National Test Lab Requirement

The display module will satisfy all requirements for compliance to the following requirement:

| | |
|-------------------------------|---|
| UL 1950, First Edition | U.S.A. Information Technology Equipment |
| CSA C22.2 No.950-M89 | Canada, Information Technology Equipment |
| IEC 950 | International, Information Technology Equipment |
| EN 60 950 | International, Information Processing Equipment (European Norm for IEC950) |

The construction of the display module is designed to suppress EMI. When mounted into a specified host system, the system will meet the following EMI requirement:

FCC Part 15 Class B
VCCI Class 2
CISPR 22, class B
Taiwan CNS standard
China CCIB standard

15.0 Label



(C) Copyright AU Optronics, Inc.

Feb. 2003 All Rights Reserved.

No Reproduction and Redistribution Allowed.

M150XN07 Ver0.1

24/28

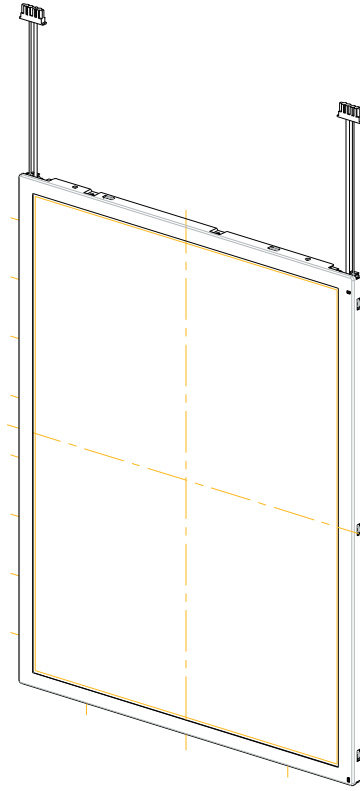

- NOTE:
- 1.THE DIMENSION EXCLUDES DEFORMATION.
 - 2.TOLERANCE WITHOUT NOTICED TO BE $\pm 0.5\text{mm}$
 - 3.LAMP CABLE CONNECTOR TO BE JST BHR-03VS-1.
 - 4.I/F CONNECTOR TO BE CWY 20G-A0DIP
 - 5.M2 STAND-OFF TORQUE 2.0 KGF-cm MAX.
 - 6.TORQUE OF M3 USER HOLE SHOULD BE WITHIN 4.0 KGF-cm AND RESCREW 10 TIMES.
 - 7.GAP BETWEEN BEZEL FRONT INNER WALL AND UPPER POLARIZER TO BE $\pm 0.5\text{mm}$ MAX.
 - 8.GAP BETWEEN BEZEL FRONT AND SHIELDING PLATE TO BE $\pm 0.5\text{mm}$ MAX.
 - 9.CHECK CODE: ① ~ ③

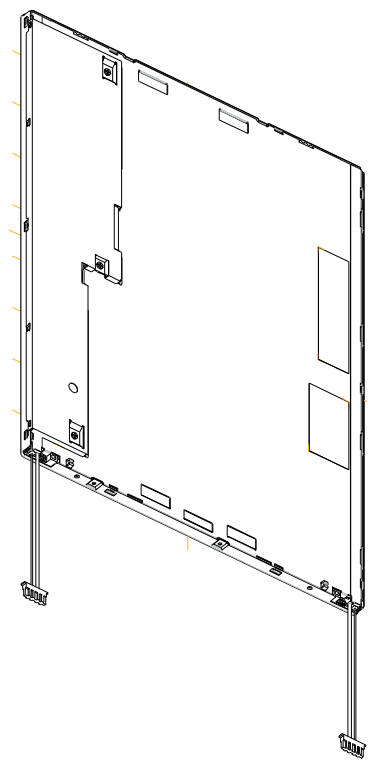

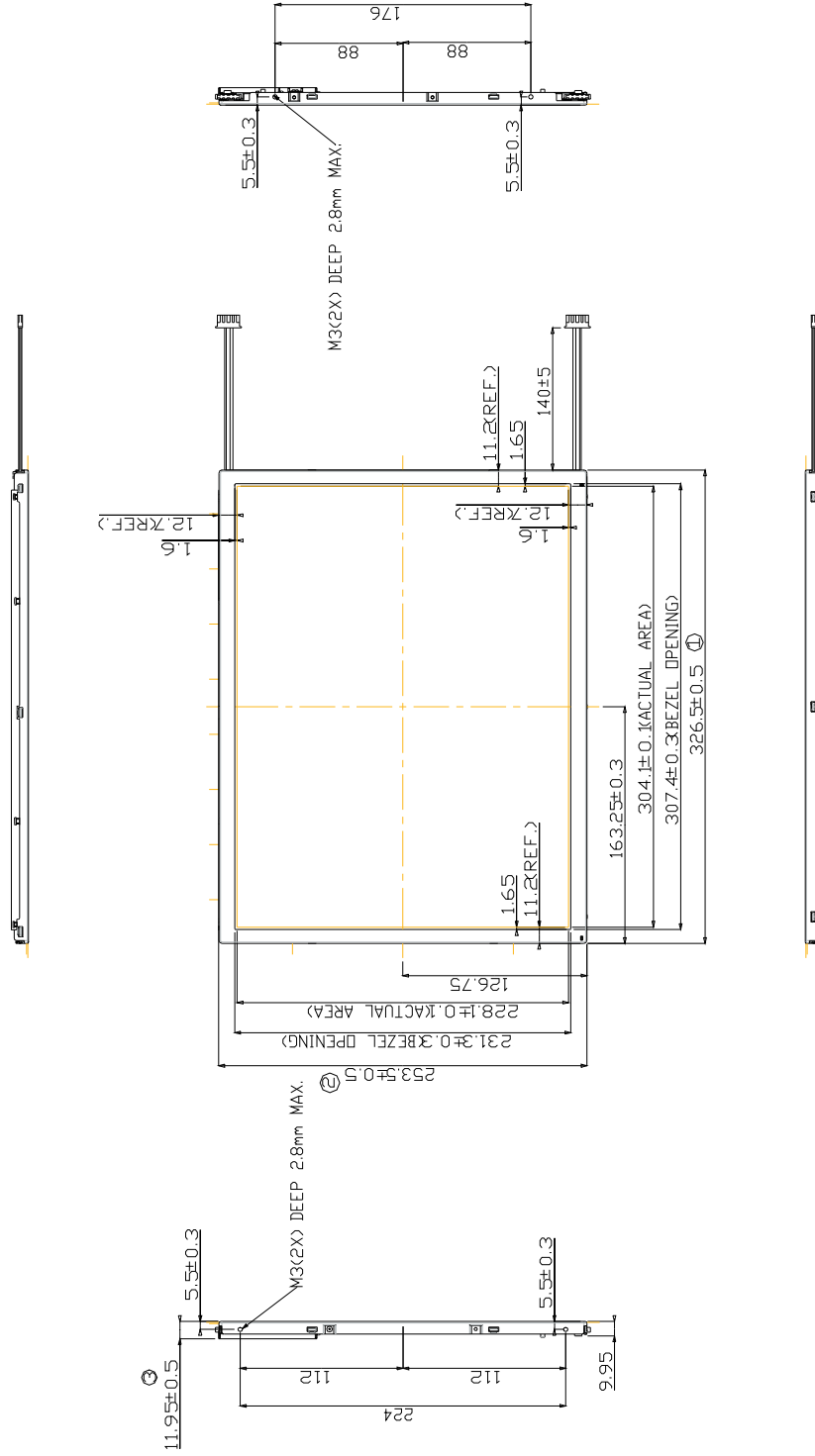

(C) Copy

Feb. 2003 All Rights Reserved.

No Reproduction and Redistribution Allowed.

M1150XN07

Ver0.1

26/28

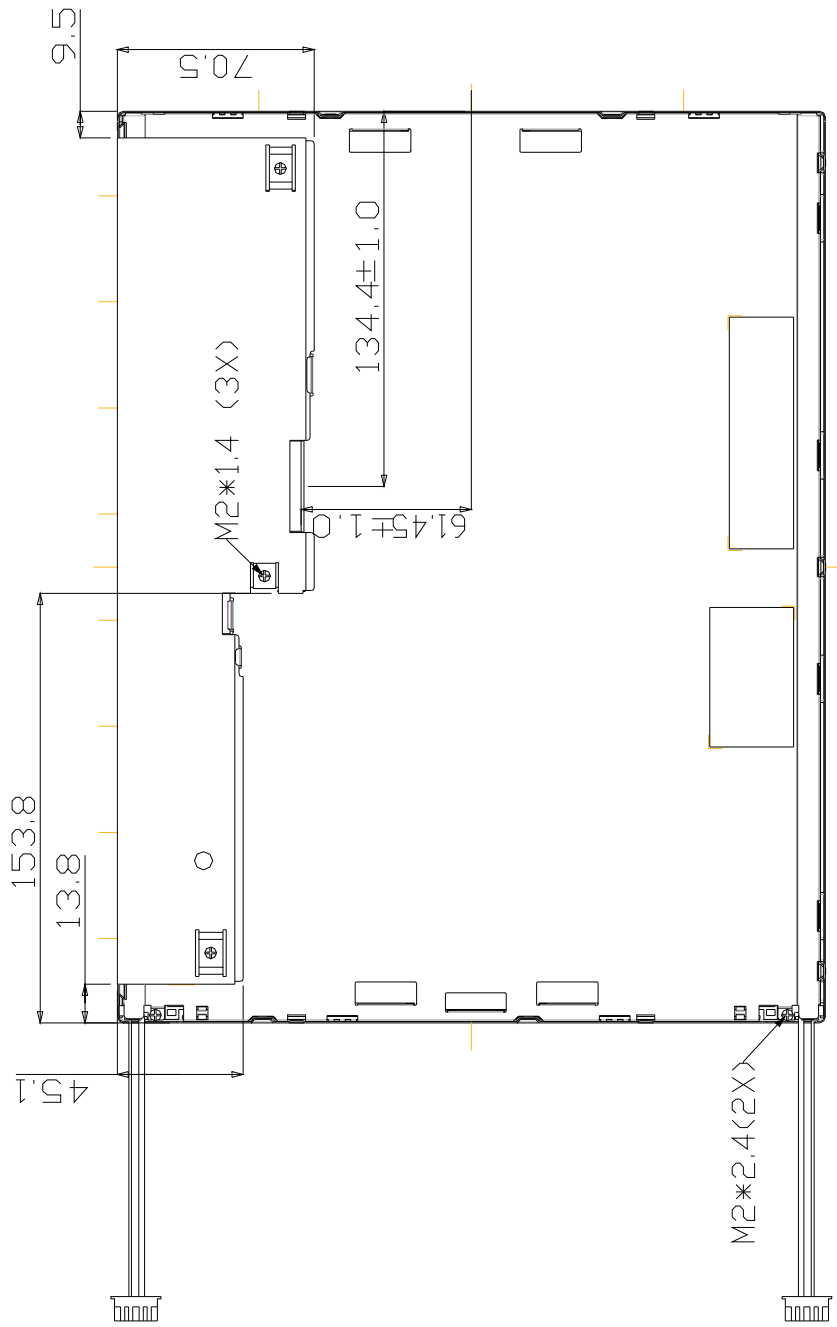

(C) Copyright AU Optronics, Inc.
 Feb. 2003 All Rights Reserved.
 No Reproduction and Redistribution Allowed.

M150XN07 Ver0.1

27/28